



Submittal Package By Garrett Haflich

OPUD Water Main & Service Line Material

**OLIVEHURST PUBLIC UTILITY DISTRICT**  
**NOTICE OF REQUEST FOR SEALED BID'S**

(DATE) MAY 21, 2026

OWNER: **Olivehurst Public Utility District**  
PROJECT: **OPUD WATER MAIN & SERVICE LINE MATERIAL RFB**

TO: Contractor / Bidder

BID DUE DATE: June 12, 2026 2:00 P.M.

BID OPENING DATE/TIME: June 12, 2026 Shortly after Bid Due Date.

SUBMIT BID

TO: **Olivehurst Public Utility District**  
1970 9th Avenue  
Olivehurst, CA 95961  
(530) 682-0736

Notice is hereby given to all prospective Contractors /Suppliers to **submit a sealed BID** on or before the above date. Contractor / Supplier agree to supply all equipment described in the available CONTRACT DOCUMENTS consisting of Plans, proposal document and Specifications. OPUD is looking for BIDS for the purchase of various water service material and pipe material. Copies of the CONTRACT DOCUMENTS may be obtained from Olivehurst Public Utility District, upon the non-refundable payment of \$ 50 per set, or you may request a free electronic copy from the District Public Works Manager via email at [sboyal@opud.org](mailto:sboyal@opud.org).

Any question should be submitted to the Public Works manager via email at [sboyal@opud.org](mailto:sboyal@opud.org) or via phone at 530-682-0736. All **questions are due by Wednesday, June 3rd at 2 PM** for Clarification or addendum items.

Sincerely,

*Swarnjit Boyal*

Swarnjit Boyal, MS  
Public Works Manager

**OLIVEHURST PUBLIC UTILITY DISTRICT**  
1970 9<sup>TH</sup> Avenue  
Olivehurst, CA 95961  
Phone: (530) 682-0736

**OLIVEHURST PUBLIC UTILITY DISTRICT**

*Our mission is to provide high quality services to enhance our community's quality of life.*



**BOARD OF DIRECTORS**

Dennise Burbank Lacey Nelson John Floe Mary Jane Griego Marc Perrault

**GENERAL MANAGER**

John Tillotson

May 21st, 2026

To: Prospective Bidders

RE: Purchase of aforementioned Water Service Materials for Service Line Replacements throughout Historic Olivehurst

Bids shall include any and all taxes, freight, federal/state fees, hazardous waste disposal fee, weight certificate of completed unit, etc. and be an 'Out-The-Door' cost. Please make sure to include a specification page/build sheet of materials in order to verify compliance with the requested specifications above. Any questions shall be directed to the OPUD Public Works Department at 530-682-0736 or via email at [sboyal@opud.org](mailto:sboyal@opud.org). Attached please find an example of what OPUD is looking for (or similar). Item # & MFG# was used as sample from local vendor as reference only. Olivehurst Public Utility District will be accepting as specified below:

**Bid FORM for following water service materials:**

Underground Republic Waterworks  
 Garrett Haflich - (916) 747-1655

RFB - BID SHEET FOR WATER SERVICES MATERIAL SUBMITAL - BID FORM										
Title	Brand	Item #	MFG #	Unit of Measure	Quantity	Price	TOTAL			
1	1B-25028N Ball Corporation Stop, 1 in, MNPT x 1/10 CTS, Brass	MUEB25028N1	025028330N	Each	160	\$78.00/ea	\$12,480.00			
2	Angle Meter Valve, 1 in, 1/10 CTS x Meter Nut, Brass	MUEB24258N1	024258330N	Each	160	\$139.00/ea	\$22,240.00			
3	Bushing, 5/8 x 3/4 to 1 in, MNPT x Meter Nut, Brass	MUEH10879N56341	1H-10879N 5/8X3/4X1	Per Pair	80	\$17.00/ea	\$1,360.00			
4	Potable Water Polyethylene Pipe, SDR 9, 4710, 1 in, 100 ft L, CTS	WPP1100BLK	WPP1100BLK	Per Roll	35	\$54.00/ea	\$1,890.00			
5	Double Strap Pipe Saddle, 10 in, 1 in FNPT	MCD3826101	4148-065	Each	30	\$202.00/ea	\$6,060.00			
6	Hinged Pipe Saddle, 8 in, 1 in FNPT	FORS91804	S91-804	Each	10	\$82.00/ea	\$820.00			
7	Double Strap Pipe Saddle, 8 in, 1 in FNPT	MCD382681	4148-015	Each	95	\$163.00/ea	\$15,485.00			
8	2-Piece Pipe Saddle, 12 in, 1 in FNPT	FORS91204	S91-1204	Each	30	\$238.00/ea	\$7,140.00			
9	Tracer Wire, 10 AWG, 45 mil, Blue, (500 ft rolls or spool)	TRW10BLU45	TRW10BLU45	Each	8	\$185.00/ea	\$1,480.00			
10	Copper Split Bolt Connector (Needs to be compatible with 10 AWG Tracer wire mentioned above)	TRWCSBCS8	TRWCSBCS8	Each	160	\$4.00/ea	\$640.00			
11	DR 18 PVC Pipe, 6 in, Bell x plain, 20 ft L sticks, Blue	PVPDR186	PVPDR186	LF	20	\$9.00/ft	\$180.00			
12	DR 18 PVC Pipe, 8 in, Bell x plain, 20 ft L sticks, Blue	PVPDR188	PVPDR188	LF	300	\$15.50/ft	\$4,650.00			
13	DR 18 PVC Pipe, 12 in, Bell x plain, 20 ft L sticks, Blue	PVPDR1812	PVPDR1812	LF	20	\$32.65/ft	\$653.00			
14	Cross, 12 x 8 in, Flange, Cement Lined	DCFROSSFLG128	DCFROSSFLG128	Each	1	\$1,700.00/ea	\$1,700.00			
15	Reducer Coupling, 8 x 6 in, Flange, Cement Lined	DOFREDFLG86	DOFREDFLG86	Each	1	\$310.00/ea	\$310.00			
16	Reducer Coupling, 12 x 8 in, Flange, Cement Lined	DOFREDFLG128	DOFREDFLG128	Each	1	\$668.50/ea	\$668.50			
17	22.5 deg Elbow, 8 in, Mechanical Joint, Fusion Bond Epoxy Coated	DCF22212M18	DCF22212M18	Each	2	\$257.50/ea	\$515.00			
18	22.5 deg Elbow, 8 in, Mechanical Joint x Flange, Cement Lined	DCF2212MJFLG8	DCF2212MJFLG8	Each	1	\$183.25/ea	\$183.25			
19	Non-Rising Stem Gate Valve, 8 in, Flange, Ductile Iron	WGVFF8	WGVFF8	Each	2	\$1,374.00/ea	\$2,748.00			
20	Non-Rising Stem Gate Valve, 12 in, Mechanical Joint x Flange, Ductile Iron	WGVMF12	WGVMF12	Each	1	\$2,538.50/ea	\$2,538.50			
21	Non-Rising Stem Gate Valve, 6 in, Flange, Ductile Iron	WGVFF6	WGVFF6	Each	1	\$879.25/ea	\$879.25			
22	Gland, 6 in, Mechanical Joint, PVC, Steel Hardware, Domestic	STTDRETPVCAIS6	PVCPKSA006G2DD	Each	2	\$67.00/ea	\$134.00			
23	Gland, 8 in, Mechanical Joint, PVC, Steel Hardware, Domestic	STTDRETPVCAIS8	PVCPKSA008G2DD	Each	3	\$90.00/ea	\$270.00			
24	Gland, 12 in, Mechanical Joint, PVC, Steel Hardware, Domestic	STTDRETPVCAIS12	PVCPKSA012G2DD	Each	1	\$164.00/ea	\$164.00			
25	Bolt Set, 10 to 12 in 150#, Zinc CR+3, Grade 2	WBLBS1012	WBLBS1012	Each	2	\$21.00/ea	\$42.00			
26	Bolt Set, 8 in 150#, Zinc CR+3, Grade 2	WBLBS8	WBLBS8	Each	8	\$8.50/ea	\$68.00			
27	Ring Gasket, 8 in, Star Title	STAR8	FAH08RG	Each	4	\$19.00/ea	\$76.00			
28	Ring Gasket, 6 in, Star Title	STAR6	FAH06RG	Each	4	\$13.00/ea	\$52.00			
29	Full Face Gasket, 12 in, Star Title	STAR12	FAH12FFG	Each	2	\$31.00/ea	\$62.00			
30	Full Face Gasket, 8 in, Star Title	STAR8	FAH08FFG	Each	2	\$20.00/ea	\$40.00			
31	860 Transition Coupling, 12 in, Various, Carbon Steel	HVM2CP1G12	860-540-0315-16	Each	1	\$664.50/ea	\$664.50			
32	874 Transition Coupling, 8 in, Flange x Various, Carbon Steel	HVMFA8	874-54-08021712	Each	1	\$574.50/ea	\$574.50			
33	22.5 deg Elbow, 6 in, Mechanical Joint x Flange, Cement Lined	DCF2212MJFLG6	DCF2212MJFLG6	Each	1	\$198.25/ea	\$198.25			
34						TAX (8.25%)	\$7,174.67			
						SUM	\$94,140.42			

# SUBMITTAL DATA SHEET

NL Ball Style Corporation Stop – 74704BQ

MNPT x Q CTS Compression

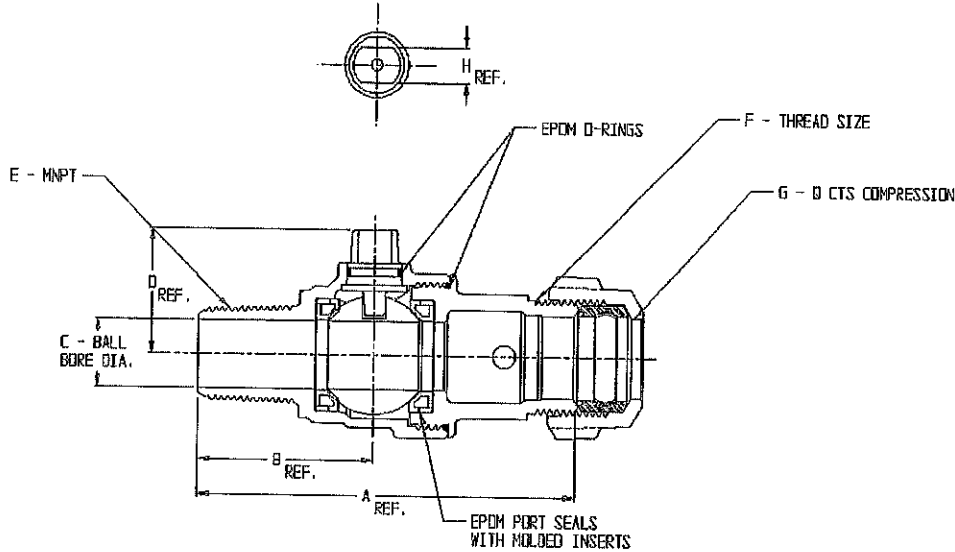

MODEL	SIZE	A	B	C	D	E	F	G	H
74704BQ	3/4	4.22	1.96	.75	1.39	3/4	3/4 ANWA FLARE	3/4	.38
74704BQ	1	4.37	2.11	1.00	1.50	1	1 ANWA FLARE	1	.28
74704BB	1 X 1 1/4	4.63	2.15	1.00	1.47	1	1 1/4 ANWA FLARE	1 1/4	.28
74704BQ	1 1/4	5.90	3.02	1.25	1.88	1 1/4	1 1/4 ANWA FLARE	1 1/4	.42
74704BQ	1 1/2	6.42	3.05	1.50	2.15	1 1/2	2 1/8-16 SPECIAL	1 1/2	.42
74704BQ	1 1/2 X 2	6.97	3.05	1.50	2.15	1 1/2	2 5/8-16 SPECIAL	1 1/2	.38
74704BQ	2	6.86	3.21	2.00	2.46	2	2 5/8-16 SPECIAL	2	.42

## SUBMITTAL INFORMATION

- Manufactured in compliance with ANSI/AWWA C800 (latest revision)
- Brass components in contact with potable water conform to ASTM B584, UNS C89833 (latest revision) and identified with "NL"
- Certified to NSF/ANSI 61 and NSF/ANSI 372
- Brass components not in contact with potable water conform to ASTM B62 and ASTM B584, UNS C83600 -85-5-5-5 (latest revision)
- PTFE coated brass ball rotates 360°
- Valve rated for 300 PSIG water pressure, end connections not to exceed rated pipe pressures.
- Blow out proof EPDM port seals
- End piece joint sealed with an EPDM o-ring and thread locker
- Insert stiffeners required on all flexible plastic connections



A.Y. McDonald Mfg. Co.  
P.O. Box 508  
Dubuque, IA 52004-508

Toll Free: 1-800-292-2737  
Fax: 1-800-832-9296  
Hours: 7:00 a.m. – 5:00 p.m., CST

sales@aymcdonald.com  
[www.aymcdonald.com](http://www.aymcdonald.com)

A.Y. McDonald considers the information on this assembly drawing correct when published. Item and option availability, including specifications, are subject to change without notice.

Submitted by:

# SUBMITTAL DATA SHEET

## NL Ball Style Meter Stop – 74602BSQ

Q CTS Compression x Meter Nut W/Saddle

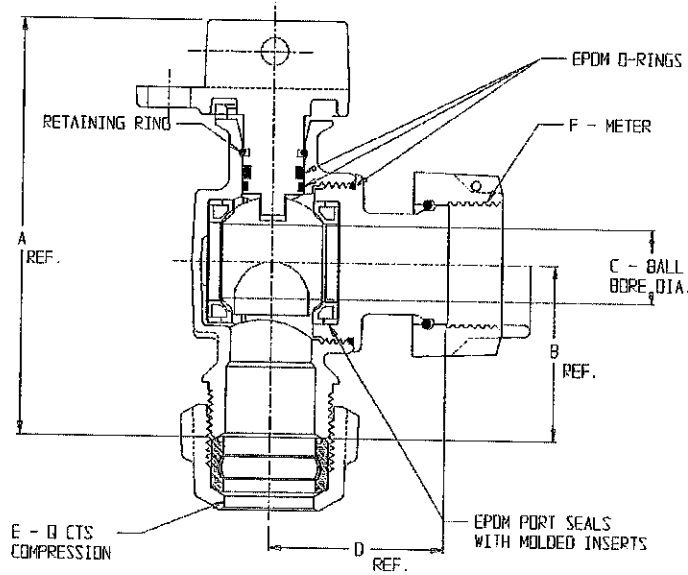

MODEL	SIZE	A	B	C	D	E	F
74602BSQ	3/4 X 3/4 X 5/8	4.20	1.78	.75	1.94	3/4	5/8
74602BSQ	1 X 3/4 X 5/8	4.64	2.21	.75	1.94	1	5/8
74602BSQ	3/4	4.20	1.78	.75	1.78	3/4	5/8 X 3/4, 3/4
74602BSQ	1 X 3/4 X 3/4	4.64	2.21	.75	1.78	1	5/8 X 3/4, 3/4
74602BSQ	1	4.90	2.25	1.00	2.45	1	1
74602BSQ	1 1/4 X 1 X 1	5.15	2.50	1.00	2.45	1 1/4	1

### SUBMITTAL INFORMATION

- Manufactured in compliance with ANSI/AWWA C800 (latest revision)
- Brass components in contact with potable water conform to ASTM B584, UNS C89833 (latest revision) and identified with "NL"
- Certified to NSF/ANSI 61 and NSF/ANSI 372
- Brass components not in contact with potable water conform to ASTM B62 and ASTM B584, UNS C83600 -85-5-5-5 (latest revision)
- PTFE coated brass ball
- Valve rated for 300 PSIG water pressure, end connections not to exceed rated pipe pressure.
- Blow out proof EPDM port seals
- End piece joint sealed with an EPDM o-ring and thread locker
- Insert stiffeners required on all flexible plastic connections



A.Y. McDonald Mfg. Co.  
4800 Chavenelle Rd  
Dubuque, IA 52002

Toll Free: 1-800-292-2737  
sales@aymcdonald.com  
[aymcdonald.com](http://aymcdonald.com)

A.Y. McDonald considers the information on this assembly drawing correct when published. Item and option availability, including specifications, are subject to change without notice.

Submitted by:

# SUBMITTAL DATA SHEET

## NL Meter Coupling - 710J24

Female Meter Thread x Male Meter Thread

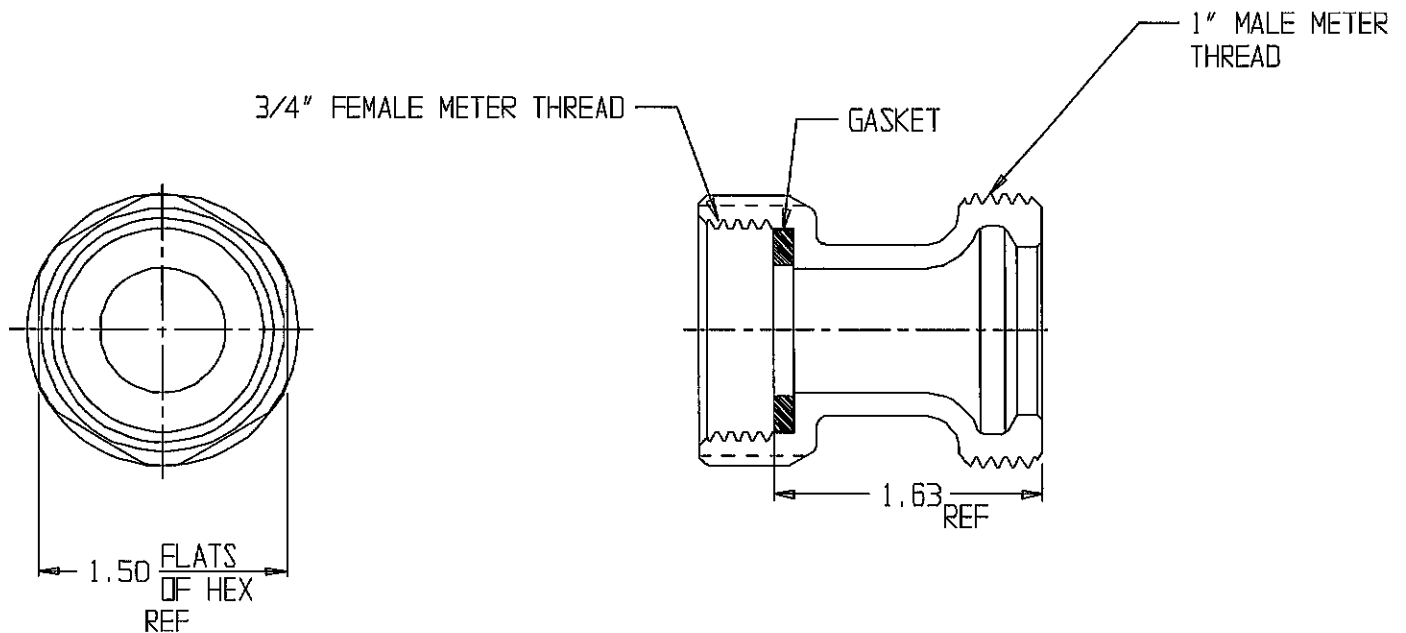

### SUBMITTAL INFORMATION

- Manufactured in compliance with ANSI/AWWA C800 (latest revision)
- Brass components in contact with potable water conform to ASTM B584, UNS C89833 (latest revision) and identified with "NL"
- Certified to NSF/ANSI 61 and NSF/ANSI 372
- Brass components not in contact with potable water conform to ASTM B62 and ASTM B584, UNS C83600 -85-5-5-5 (latest revision)
- Large wrench area provided for proper installation



**A.Y. McDonald Mfg. Co.**  
4800 Chavenelle Rd  
Dubuque, IA 52002

**Toll Free: 1-800-292-2737**  
[sales@aymcdonald.com](mailto:sales@aymcdonald.com)  
[aymcdonald.com](http://aymcdonald.com)

A.Y. McDonald considers the information on this assembly drawing correct when published. Item and option availability, including specifications, are subject to change without notice.

**Submitted by:**

09-14



# CenFuse

Flexible Polyethylene Pipe

HDPE 4710 – ASTM D3035 & ASTM F714

Certified and Listed NSF

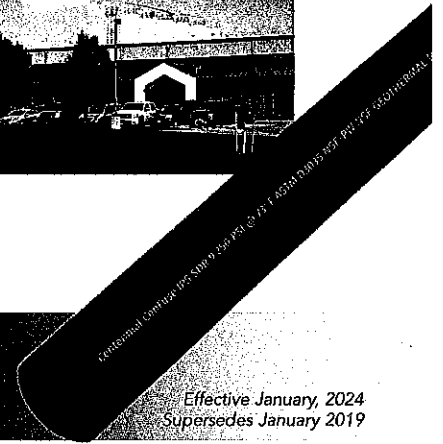

Effective January, 2024  
Supersedes January 2019

ASTM D3035			DR 7	DR9	DR 11	DR 13.5	DR 15.5	DR 17
Dimensions	OD	DR	335 PSI	250 PSI	200 PSI	160 PSI	138 PSI	125 PSI
3/4"	1.050	ID (in)	0.750	0.816	0.860	0.894	0.914	0.926
		Min Wall (in)	0.150	0.117	0.095	0.078	0.068	0.062
		Wt/Ft (lbs)	0.181	0.146	0.122	0.102	0.098	0.082
1"	1.315	ID (in)	0.939	1.023	1.075	1.121	1.145	1.161
		Min Wall (in)	0.188	0.146	0.120	0.097	0.085	0.077
		Wt/Ft (lbs)	0.285	0.229	0.191	0.159	0.151	0.128
1 1/4"	1.660	ID (in)	1.186	1.292	1.358	1.414	1.446	1.464
		Min Wall (in)	0.237	0.184	0.151	0.123	0.107	0.098
		Wt/Ft (lbs)	0.453	0.365	0.306	0.254	0.223	0.206
1 1/2"	1.900	ID (in)	1.358	1.478	1.554	1.618	1.654	1.676
		Min Wall (in)	0.271	0.211	0.173	0.141	0.123	0.112
		Wt/Ft (lbs)	0.593	0.479	0.402	0.333	0.294	0.269
2"	2.375	ID (in)	1.697	1.847	1.943	2.023	2.069	2.095
		Min Wall (in)	0.339	0.264	0.216	0.176	0.153	0.140
		Wt/Ft (lbs)	0.928	0.749	0.627	0.520	0.457	0.421
3"	3.500	ID (in)	2.500	2.722	2.864	2.982	3.048	3.088
		Min Wall (in)	0.500	0.389	0.318	0.259	0.226	0.206
		Wt/Ft (lbs)	2.016	1.626	1.360	1.128	0.994	0.912

CENTENNIAL CenFuse IPS SDR 9 250PSI @ 73°F ASTM D3035 NSF-pw NSF geothermal AWWA C901 NSF358 PE4710 CC3

ASTM F714			DR 7	DR9	DR 11	DR 13.5	DR 15.5	DR 17
Dimensions	OD	DR	335 PSI	250 PSI	200 PSI	160 PSI	138 PSI	125 PSI
4"	4.500	ID (in)	3.214	3.500	3.682	3.834	3.920	3.970
		Min Wall (in)	0.643	0.500	0.409	0.333	0.290	0.265
		Wt/Ft (lbs)	3.402	2.688	2.249	1.865	1.641	1.506
6"	6.625	ID (in)	—	5.153	5.421	5.643	5.771	5.845
		Min Wall (in)	—	0.736	0.602	0.491	0.427	0.390
		Wt/Ft (lbs)	—	5.961	4.873	4.048	3.557	3.268
8"	8.625	ID (in)	—	—	7.057	7.347	7.513	7.611
		Min Wall (in)	—	—	0.784	0.639	0.556	0.507
		Wt/Ft (lbs)	—	—	8.263	7.035	6.043	5.535

CENTENNIAL CenFuse IPS SDR 9 250PSI @ 73°F ASTM F714 NSF-pw NSF geothermal AWWA C906 NSF358 PE4710 CC3

Note: For stocking coil lengths, please see centennialplastics.com

DR 9 = Water Service Pipe AWWA C901 & C906 Black with Blue stripe CC3



Scan here to learn more about our Geothermal Pipe

## ESSENTIAL LINKS (click link for website or to download file)

- » PE Handbook
- » Plastic Pipe Design Calculator
- » Temperature Effects on Centennial Poly (HDPE App)
- » CenFuse Stocking Coil Lengths
- » Chemical Resistance of Plastic Piping Materials
- » Weatherability of Thermoplastic Piping Systems

Dimension Ratio, DR	Min Cold Bend Radius
7, 9	20 x Pipe OD
11, 13.5	25 x Pipe OD
15.5, 17	27 x Pipe OD

## CERTIFICATIONS & REFERENCES

- » **Centennial CenFuse Polyethylene Pipe** is compatible for connections with butt fusion, socket fusion, electrofusion, compression fittings, and victaulic grooved fittings. Check with fitting manufacturers for proper installation.
- » **CenFuse DR 9 and 7 meet AWWA C901** requirements in 3/4"- 3" and **AWWA C906** requirements in 4"- 6". CenFuse is certified and tested by NSF/ANSI standard 61 for potable water contact and NSF 14 for product performance compliance.
- » **NSF/ANSI/CAN 61** — Drinking Water System Components-Health Effects establishes the benchmark criteria for evaluating health effects of many drinking water system components, including plastic piping. Includes annual monitoring testing to verify continuous compliance, regular unannounced inspections of the manufacturing location, and ensures pipe is suitable for drinking water.
- » **NSF/ANSI 14** — Plastics Piping System Components and Related Materials establishes the physical, performance and health effects requirements for plastics piping system components and related materials. Includes annual monitoring testing to verify continuous compliance, regular unannounced inspections of the manufacturing location, and testing to product standards such as ASTM for dimensions, burst, sustained pressure, crush, extrusion quality, etc. Along with verification of the pipe material's long-term strength rating and material physical properties.
- » **ASTM D3035** — This specification covers polyethylene (PE) pipe made in thermoplastic pipe dimension ratios based on outside diameter IPS 3/4 to 3, for both non-pressure and pressure rated water. Included are requirements for polyethylene compounds and PE plastic pipe, a system of nomenclature for PE plastic pipe, and requirements and test methods for materials, workmanship, dimensions, sustained pressure, and burst pressure.
- » **ASTM F714** — This specification covers polyethylene (PE) pipe 4" and larger.
- » **PE4710** — CenFuse is manufactured from virgin high density polyethylene resin with the cell classification of 445576C per ASTM D3350-22. The material contains minimum 2% carbon black as a UV inhibitor to accommodate outside storage for at least 18 months
- » **ASTM D3350** — Material shall be high-density polyethylene conforming to the minimum requirements of cell classification 445576C. DR 9 or 250 psi related pipe will be listed CC3.
- » **ASTM F2620** — Heat fusion joining an PPI TR-33/R-41.
- » **AWWA C901** — This standard describes polyethylene (PE) pressure pipe and tubing made from material having standard PE code designation PE4710 and intended for use in potable water, reclaimed water, and wastewater service. Conforms to the OD dimensions of copper tube size (CTS) and iron pipe size (IPS). Pipe sizes 3" and smaller.
- » **AWWA C906** — This standard describes polyethylene (PE) pressure pipe and fittings made from materials conforming to standard PE materials designation codes PE 2606, PE 2706, PE 2708, PE 3608, PE 3708, PE 3710, PE 4608, PE 4708, and PE 4710. HDPE 4" and larger
- » **CenFuse** is certified to NSF/ANSI 372 and conforms with the "lead free" plumbing as defined by California, Vermont, Maryland, and Louisiana state laws and the U.S. Safe Drinking Water Act.
- » **Build America, Buy America (BABA Act)** — We proudly hold a BABA Act certification.
- » **Centennial Plastics follows Proposition 65** – [www.P65Warnings.ca.gov](http://www.P65Warnings.ca.gov)  
Our products in their finished form do not require a California Proposition 65 warning label.



centennialplastics.com



10/24

NEBRASKA  
1830 Centennial Ave.  
Hastings, NE 68901

IDAHO  
5150 Treasure Valley Way  
Nampa, ID 83687

info@centennialplastics.com  
402-462-2227

# SUBMITTAL DATA SHEET

## Silicon Bronze Strap Saddle - 3826

Ductile Iron/Cement-Asbestos/Cast Iron x FNPT



MODEL	SIZE	A	B	C	D	E	F
3826	4 X 3/4	3/4	3.19	3.19	1.69	HEX	4.74 - 5.40
3826	4 X 1	1	3.19	3.19	1.69	HEX	4.74 - 5.40
3826	4 X 1 1/2	1 1/2	3.19	4.19	3.10	DCT	4.74 - 5.40
3826	4 X 2	2	3.19	4.19	3.10	DCT	4.74 - 5.40
3826	6 X 3/4	3/4	3.19	3.19	1.69	HEX	6.84 - 7.50
3826	6 X 1	1	3.19	3.19	1.69	HEX	6.84 - 7.50
3826	6 X 1 1/4	1 1/4	3.19	4.19	3.10	DCT	6.84 - 7.50
3826	6 X 1 1/2	1 1/2	3.19	4.19	3.10	DCT	6.84 - 7.50
3826	6 X 2	2	3.19	4.19	3.10	DCT	6.84 - 7.50
3826	8 X 3/4	3/4	3.19	3.19	1.69	HEX	8.99 - 9.67
3826	8 X 1	1	3.19	3.19	1.69	HEX	8.99 - 9.67
3826	8 X 1 1/4	1 1/4	3.19	4.19	3.10	DCT	8.99 - 9.67
3826	8 X 1 1/2	1 1/2	3.19	4.19	3.10	DCT	8.99 - 9.67
3826	8 X 2	2	3.19	4.19	3.10	DCT	8.99 - 9.67
3826	10 X 3/4	3/4	3.19	3.19	1.69	HEX	11.04 - 12.12
3826	10 X 1	1	3.19	3.19	1.69	HEX	11.04 - 12.12
3826	10 X 1 1/2	1 1/2	3.19	4.19	3.10	DCT	11.04 - 12.12
3826	10 X 2	2	3.19	4.19	3.10	DCT	11.04 - 12.12
3826	12 X 3/4	3/4	3.19	3.19	1.69	HEX	13.20 - 14.38
3826	12 X 1	1	3.19	3.19	1.69	HEX	13.20 - 14.38
3826	12 X 1 1/2	1 1/2	3.19	4.19	3.10	DCT	13.20 - 14.38
3826	12 X 2	2	3.19	4.19	3.10	DCT	13.20 - 14.38
3826	18 X 3/4	3/4	4.93	5.00	3.48	DCT	19.50 - 20.50
3826	18 X 1	1	4.93	5.00	3.48	DCT	19.50 - 20.50
3826	18 X 1 1/2	1 1/2	4.93	5.00	3.48	DCT	19.50 - 20.50
3826	18 X 2	2	4.93	5.00	3.48	DCT	19.50 - 20.50
3826	30 X 3/4	3/4	4.93	5.00	3.48	DCT	31.74 - 32.74
3826	30 X 1	1	4.93	5.00	3.48	DCT	31.74 - 32.74
3826	30 X 1 1/2	1 1/2	4.93	5.00	3.48	DCT	31.74 - 32.74
3826	30 X 2	2	4.93	5.00	3.48	DCT	31.74 - 32.74

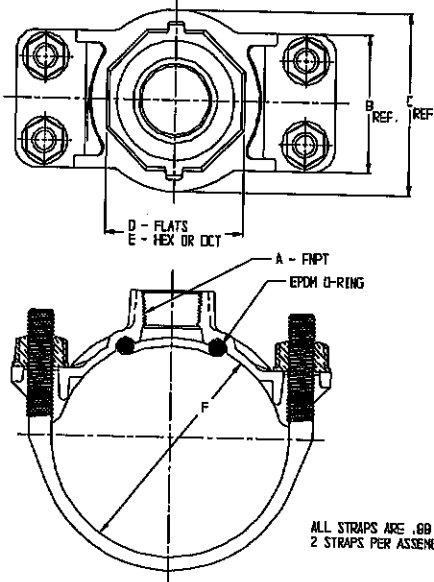

DRAWING MAY NOT RESEMBLE ACTUAL SADDLE CONFIGURATION

### SUBMITTAL INFORMATION

- Manufactured in compliance with ANSI/AWWA C800 (latest revision)
- Brass components conform to ASTM B62 and ASTM B584, UNS C83600 -85-5-5-5 (latest revision)
- Certified to NSF/ANSI 61
- Silicon Bronze strap(s) and cast brass nuts with enlarged washer bearing surface
- EPDM o-ring
- Pipe and tap size, and thread type identified on saddle
- Outlet boss with large wrench flats



A.Y. McDonald Mfg. CO.  
P.O. Box 508  
Dubuque, IA 52004-508

Toll Free: 1-800-292-2737  
Fax: 1-800-832-9296  
Hours: 7:00 a.m. - 5:00 p.m., CST

sales@aymcdonald.com  
[www.aymcdonald.com](http://www.aymcdonald.com)

A.Y. McDonald considers the information on this assembly drawing correct when published. Item and option availability, including specifications, are subject to change without notice.

Submitted by:

# SUBMITTAL DATA SHEET

## Hinged Saddle - 3896

C900 PVC x FNPT



MODEL	SIZE	A	B	C	D	E	F	G	TITAN BOLT
3896	4 X 3/4	3/4	2.00	2.56	1.69	HEX	4.800	1	YES
3896	4 X 1	1	2.00	2.56	1.69	HEX	4.800	1	YES
3896	4 X 1 1/2	1 1/2	2.50	3.96	3.10	OCT	4.800	2	NO
3896	4 X 2	2	2.50	3.96	3.10	OCT	4.800	2	NO
3896	6 X 3/4	3/4	2.00	2.56	1.69	HEX	6.900	1	YES
3896	6 X 1	1	2.00	2.56	1.69	HEX	6.900	1	YES
3896	6 X 1 1/2	1 1/2	2.50	3.96	3.10	OCT	6.900	2	NO
3896	6 X 2	2	2.50	3.96	3.10	OCT	6.900	2	NO
3896	8 X 3/4	3/4	2.00	2.56	1.69	HEX	9.050	1	YES
3896	8 X 1	1	2.00	2.56	1.69	HEX	9.050	1	YES
3896	8 X 1 1/2	1 1/2	2.50	3.96	3.10	OCT	9.050	2	NO
3896	8 X 2	2	2.50	3.96	3.10	OCT	9.050	2	NO

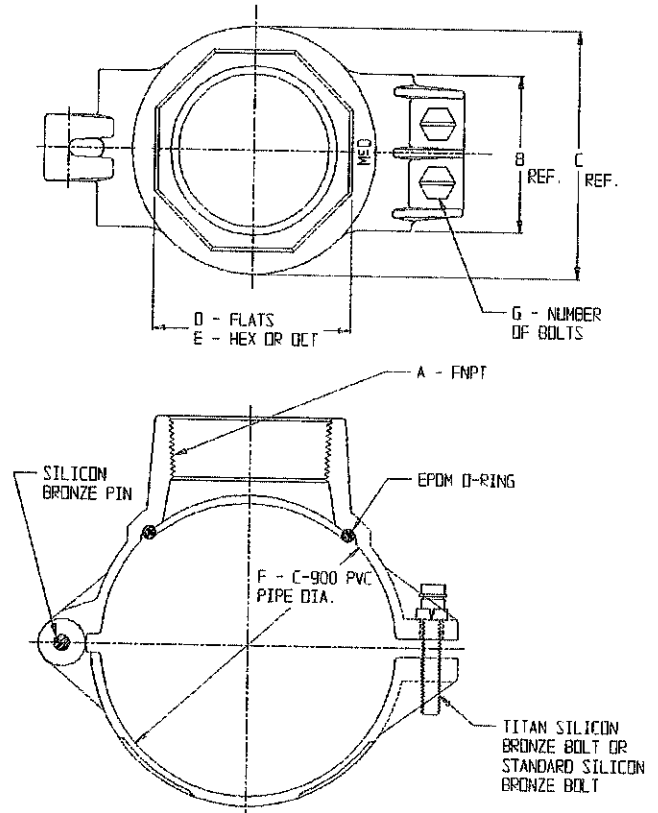

### SUBMITTAL INFORMATION

- Manufactured in compliance with ANSI/AWWA C800 (latest revision)
- Brass components conform to ASTM B62 and ASTM B584, UNS C83600 -85-5-5-5 (latest revision)
- Certified to NSF/ANSI 61
- Silicon Bronze hinge pin and bolt(s)
- EPDM o-ring
- Pipe and tap size, and thread type identified on saddle
- Outlet boss with large wrench flats



**A.Y. McDonald Mfg. CO.**  
4800 Chavenelle Rd  
Dubuque, IA 52002

Toll Free: 1-800-292-2737  
sales@aymcdonald.com  
[aymcdonald.com](http://aymcdonald.com)

A.Y. McDonald considers the information on this assembly drawing correct when published. Item and option availability, including specifications, are subject to change without notice.

Submitted by:

# SUBMITTAL DATA SHEET

## Two Piece Brass Saddle - 3806

C900 PVC x FNPT



MODEL	SIZE	A	B	C	D	E	F
3806	4 X 3/4	3/4	1.23	2.38	1.50	HEX	4.800
3806	4 X 1	1	1.32	2.55	1.72	HEX	4.800
3806	4 X 1 1/2	1 1/2	1.50	3.48	2.34	OCT	4.800
3806	4 X 2	2	1.50	3.72	2.82	OCT	4.800
3806	6 X 3/4	3/4	1.28	2.28	1.50	HEX	6.900
3806	6 X 1	1	1.24	2.58	1.72	HEX	6.900
3806	6 X 1 1/2	1 1/2	1.63	3.48	2.34	OCT	6.900
3806	6 X 2	2	1.63	3.72	2.82	OCT	6.900
3806	8 X 3/4	3/4	1.26	2.38	1.50	HEX	9.050
3806	8 X 1	1	1.26	2.58	1.72	HEX	9.050
3806	8 X 1 1/2	1 1/2	1.50	3.86	3.10	OCT	9.050
3806	8 X 2	2	1.50	3.86	3.10	OCT	9.050
3806	10 X 3/4	3/4	2.32	2.92	1.89	HEX	11.100
3806	10 X 1	1	2.32	2.92	1.89	HEX	11.100
3806	10 X 1 1/2	1 1/2	2.30	4.37	3.10	HEX	11.100
3806	10 X 2	2	2.30	4.37	3.10	HEX	11.100
3806	12 X 3/4	3/4	2.32	2.92	1.89	HEX	13.200
3806	12 X 1	1	2.32	2.92	1.89	HEX	13.200
3806	12 X 1 1/2	1 1/2	2.30	4.37	3.10	HEX	13.200
3806	12 X 2	2	2.30	4.37	3.10	HEX	13.200

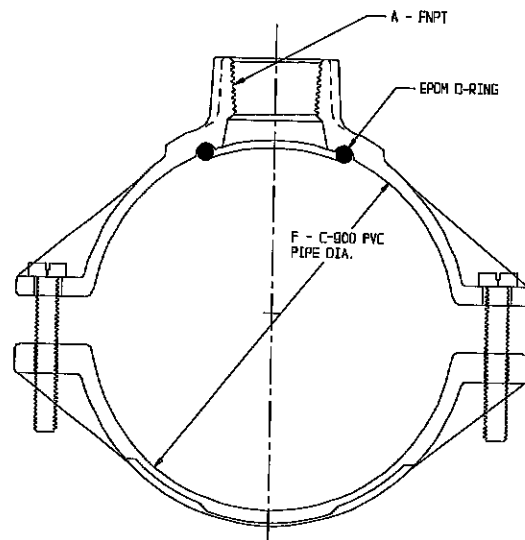
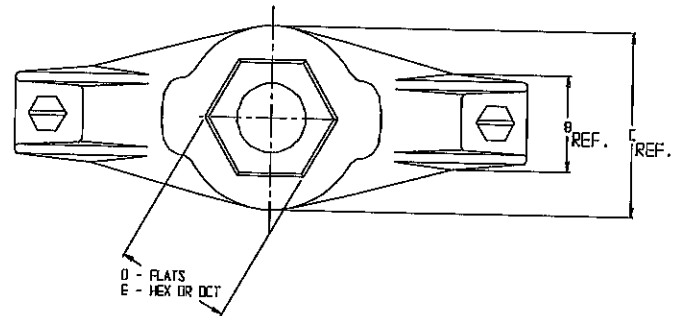

### SUBMITTAL INFORMATION

- Manufactured in compliance with ANSI/AWWA C800 (latest revision)
- Brass components conform to ASTM B62 and ASTM B584, UNS C83600 -85-5-5-5 (latest revision)
- Certified to NSF/ANSI 61
- Silicon Bronze bolts
- EPDM o-ring
- Pipe and tap size, and thread type identified on saddle
- Outlet boss with large wrench flats



A.Y. McDonald Mfg. CO.  
4800 Chavenelle Rd  
Dubuque, IA 52002

Toll Free: 1-800-292-2737  
sales@aymcdonald.com  
[aymcdonald.com](http://aymcdonald.com)

A.Y. McDonald considers the information on this assembly drawing correct when published. Item and option availability, including specifications, are subject to change without notice.

Submitted by:



# AGAVE WIRE

Toll-Free (800) 690-3408

An ISO 9001 Management System

Fax: (469) 547-4242

## PRODUCT GROUP DATA SHEET

**PRODUCT OVERVIEW:**      **APUT Copper PE(45) Tracer UL**

CONSTRUCTION:              One Copper HMW-PE Insulated Conductor

APPROVALS:                 UL - Tracer Wire

APPLICATION:              Tracer Wire Suitable for Detecting Buried Facilities

### **CONSTRUCTION PARAMETERS:**

CONDUCTOR:                 Annealed Bare Copper

NUMBER OF CONDUCTORS:      1

INSULATION MATERIAL:        HMW-PE (High Molecular Weight Polyethylene)

INSULATION THICKNESS:       0.045" Nominal

### **ELECTRICAL & ENVIRONMENTAL PROPERTIES:**

TEMPERATURE RATING:        -20°c to 80°c

OPERATING VOLTAGE:         600v

INSULATION COLOR:         Various Colors Available ← BLUE

### **PRINT LEGEND:**

AGAVE WIRE - \*\*AWG HMW-PE-(45) TRACER WIRE 600v (UL) E246360

\*\*Print line will show gauge specific to product

Part Number	AWG	Conductor Stranding	Weight per 1000 ft (lbs.)	Copper O.D.	Finished O.D. (nom)	DC Resist. @ 20 °C (Ohms/1000')	Break Load
APUT-1801	18	Solid	9.86	0.040"	0.132"	6.3200	41
APUT-1819	18	19/.0092	10.35	0.047"	0.137"	6.1000	47
APUT-1601	16	Solid	13.32	0.051"	0.142"	4.0200	65
APUT-1619	16	19/.0117	13.82	0.057"	0.147"	1.4800	74
APUT-1401	14	Solid	18.76	0.064"	0.156"	2.5240	104
APUT-1419	14	19/.0141	19.52	0.074"	0.167"	2.8300	118
APUT-1201	12	Solid	26.97	0.081"	0.172"	1.5890	165
APUT-1219	12	19/.0185	27.86	0.088"	0.178"	1.6000	186
APUT-1001	10	Solid	39.95	0.102"	0.194"	0.9988	261
APUT-1019	10	19/.0234	41.03	0.112"	0.202"	1.1000	296
APUT-0801	8	Solid	59.95	0.128"	0.220"	0.0740	450
APUT-0819	8	19/.0285	62.06	0.148"	0.238"	0.7100	472
APUT-0601	6	Solid	91.43	0.162"	0.252"	0.3952	722
APUT-0619	6	19/.0372	94.72	0.179"	0.269"	0.4500	750

On special orders, the customer will accept all mil lengths and +/- 10% of total order requested. The information presented here is, to the best of our knowledge, is true and accurate. However, since conditions of use are beyond our control, all recommendations or suggestions are presented without guarantee or responsibility on our part. We disclaim all liability in connection with the use of information contained herein or otherwise.

This specification is proprietary intellectual property of Agave Wire. Any information contained herein shall not be disclosed to any party without written consent of Agave Wire.

**Proudly Manufactured in the U.S.A.**

## Split Bolt Connectors

For use on all combinations:

- Aluminum to aluminum
- Aluminum to copper
- Copper to copper

Compact, high strength, high copper alloy split-bolt has free-running threads and easy to grip wrench flats. Highly resistant to corrosion and season cracking, these split bolt connectors provide maximum pressure and assures a secure connection on all combinations of run and tap conductors. Type KS-3 accomodates 3 maximum size conductors.

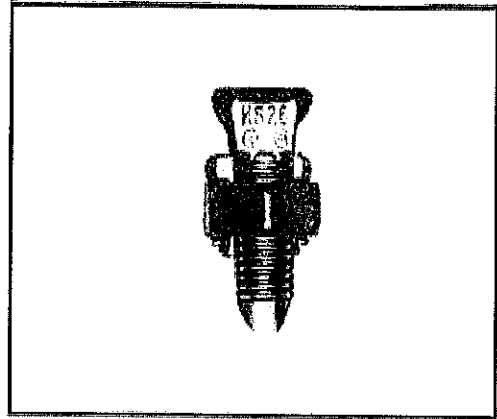

Catalog Number	Gross Flats	L	W	185 Conductor		Conductor				▲ Recommended Tightening Torque In-lb
				Copper		Copperweld				
				Range for Equal Run and Tap	Min. Tap with Max. Run	Maximum Run and Tap				
				Sol.	Str.	Type A	Type D			
† KS90	.50	.85	.38	12 Str. - 10 Str.	16 Str.	#10	—	—	—	30
† KS15	.50	.85	.38	10 Str. - 8 Str.	14 Str.	#8	—	—	—	165
† KS17	.63	1.14	.45	8 Str. - 6 Sol.	14 Str.	#6	3 #12	BA	9-1/2D	165

† In addition to UL listed for wire connectors and CSA Certified, these itmes are also rated for direct burial.

▲ Listed torque values are for maximum conductor combinations accomodated.

# VINYLTECH AWWA C900 BLUE

TECHNICAL DATA SUBMITTAL (4" - 12")

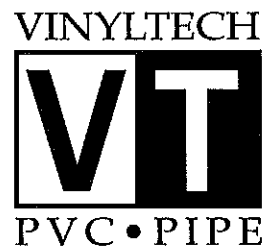

## CONFORMANCE

These specifications designate the requirements for manufacturing and installing Vinyltech AWWA C900 PVC Pressure Pipe for potable water (4"-12").

**ANSI/AWWA C900** - Polyvinyl Chloride (PVC) Pressure Pipe and Fabricated Fittings, 4" Through 60" (100mm Through 1,500mm)

**AWWA C605** - Underground Installation of Polyvinyl Chloride (PVC) Pressure Pipe and Fittings for Water

**ASTM D1784** - Standard Specification for Rigid Poly (Vinyl Chloride) (PVC) Compounds and Chlorinated Poly (Vinyl Chloride) (CPVC) Compounds

**ASTM D3139** - Standard Specification for Joints for Plastic Pressure Pipes Using Flexible Elastomeric Seals

**ASTM F477** - Standard Specification for Elastomeric Seals (Gaskets) for Joining Plastic Pipe

**NSF/ANSI 61, Annex G** - Drinking Water Systems Components-Health Effects

**FM 1612** - Approval Standard for Polyvinyl Chloride (PVC) Pipe and Fittings for Underground Fire Protection

**UL 1285** - Standard for Pipe and Couplings, Polyvinyl Chloride (PVC), and Oriented Polyvinyl Chloride (PVCO) for Underground Fire Service

## PIPE COMPOUND

The pipe shall be extruded from compounds meeting (PVC 1120) the requirements of Cell Classification 12454, as defined in ASTM D1784, Standard Specification for Rigid Poly (Vinyl Chloride) (PVC) Compounds and Chlorinated Poly (Vinyl Chloride) (CPVC) Compounds. The PVC shall also be listed by the National Sanitation Foundation (NSF) for use in potable water.

## PIPE

Vinyltech pipe shall be manufactured in accordance with AWWA C900.

## GASKET JOINT

The gasket shall be reinforced with a steel band and meet the requirements of ASTM F477. Vinyltech pipe shall have an integral bell end with a locked-in factory installed gasket and shall meet the joint requirements of ASTM D3139.

## MARKING

The pipe shall be marked in accordance with AWWA C900.

## QUALITY CONTROL

Each length of the pipe including the bell shall be hydrostatically tested in accordance with AWWA C900. The pipe shall meet all additional test requirements as described in AWWA C900. Our full-time quality assurance staff continually administers a rigid program of tests to maintain the production of the best pipe products available.

## INSTALLATION

Recommended installation procedures of Vinyltech Corporation are outlined in AWWA C605, Underground Installation of Polyvinyl Chloride (PVC) Pressure Pipe and Fittings for Water. The AWWA Manual M23, PVC Pipe Design and Installation, is also an invaluable resource guide for design and installation.

## TAPPING

The consistent success of tapping PVC pressure pipe is contingent upon the use of proper procedures and equipment. Vinyltech recommends strict compliance with the requirements as specified in AWWA C605.

## ASSEMBLING THE PIPE

Assembly of Vinyltech PVC water pipe is easily accomplished. A depth of entry mark is on each spigot end to serve as a visual check for rapid, accurate joint inspection. **Do not over insert.**

- 1) Remove any mud, sand, or other foreign matter from the belled and spigot ends of the pipe. Carefully clean the gasket area.
- 2) With a clean applicator (a brush or hand) lubricate the entire surface of the pipe from the spigot end to the depth of entry mark and the contact surface of the gasket with **Vinyltech Brand Lubricant**.
- 3) Brace the bell to avoid disturbing the already installed joints. Align the pipe, insert the spigot into the bell and push.
- 4) **Do not insert past the entry mark line.**



Underwriters  
Laboratories Inc.®  
LISTED

VINYLTECH • 201 S. 61st Avenue • Phoenix, AZ 85043 • 602 233-0071 • Fax: 602 272-4847 • www.vtpipe.com



AN OTTERTAIL COMPANY

**C900 DR 18 Pressure Class 235**

NOMINAL SIZE		OUTER DIAMETER (IN)	MINIMUM WALL (IN)	FEET PER LIFT	LIFTS PER TRUCK	APPROX WEIGHT (LB/100')
(IN)	(mm)					
4	100	4.800	0.267	1020	16	251.6
6	150	6.900	0.383	440	16	521.2
8	200	9.050	0.503	200	20	903.0
10	250	11.100	0.617	240	12	1364.4
12	300	13.200	0.733	60-80	28	1935.8

**C900 DR 14 Pressure Class 305**

NOMINAL SIZE		OUTER DIAMETER (IN)	MINIMUM WALL (IN)	FEET PER LIFT	LIFTS PER TRUCK	APPROX WEIGHT (LB/100')
(IN)	(mm)					
4	100	4.800	0.343	1020	16	317.5
6	150	6.900	0.493	440	16	658.7
8	200	9.050	0.646	200	20	1139.7
10	250	11.100	0.793	240	12	1722.3
12	300	13.200	0.943	60-80	28	2445.5

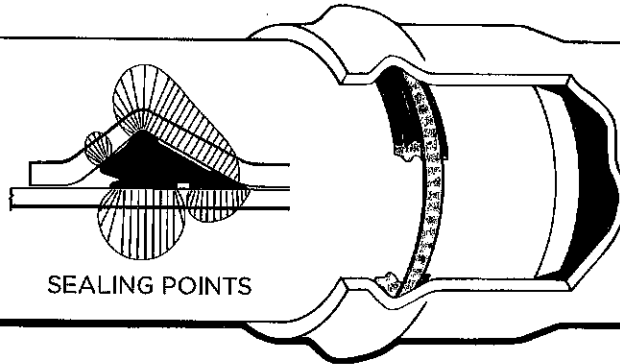

**The Rieber Sealing System**

The Rieber system provides a proven pipe joint with an excellent track record in the field. It is the fastest growing system in the world because of its many advantages.

- Factory installed, locked-in gasket
- The pipe bell forms over the gasket, making a perfect fit
- Avoids the possibility of installing the wrong gasket
- Reduces installation problems
- The locked-in gasket eliminates gasket roll-out during joining
- The gasket is molded vs. extruded and spliced
- Works equally well under pressure or vacuum
- Three sealing points achieved vs. two
- **LEAK-PROOF JOINTS**
- **"THE WORLDS BEST JOINT"**



# Ductile Iron Flanged Fittings

## ANSI/AWWA C110/A21.10

**GENERAL SPECIFICATIONS**

- MATERIAL:** Ductile iron per ASTM A536
- PRESSURE:** 250 PSI rating for 1" - 48" sizes and 150 PSI rating for 54" - 64"
- TESTING:** In accordance with ANSI/AWWA C110/A21.10, UL and FM requirements
- LAYING LENGTH:** 2" - 48" sizes in accordance with ANSI/AWWA C110/A21.10 and ANSI B16.1 and 54" - 64" sizes in accordance with ANSI/AWWA C153/A21.53 (fittings not listed in ANSI/AWWA have dimensions per Star design as noted in the catalog)
- WEIGHTS:** Are in pounds, unless noted otherwise and do not include accessories, cement lining and coatings
- DRILLING:** In accordance with ANSI/AWWA C110/A21.10, ANSI/AWWA C153/A21.53 and ANSI B16.1 Class 12S Flanges
- CEMENT LINING:** In accordance with ANSI/AWWA C104/A21.4 -- sizes 1" - 3" single thickness and sizes 4" - 64" double thickness
- COATING:** Asphaltic seal coat inside in accordance with ANSI/AWWA C104/A21.4 and prime coat outside
- APPROVALS:** 2" - 12" Underwriters Laboratories and ULC Listed and Factory Mutual approved for 300 PSI rating. Please consult factory for detail listing and approvals. 2" and greater are UL/NSF-61.
- DIMENSIONS:** All dimensions are in inches unless noted otherwise.
- INSTALLATION:** Per ANSI/AWWA C110 and C111



**SUBMITTAL INFORMATION**

**PROJECT NAME:** \_\_\_\_\_

**ENGINEER:** \_\_\_\_\_

**CONTRACTOR:** \_\_\_\_\_

**SPEC. SECTION:** \_\_\_\_\_

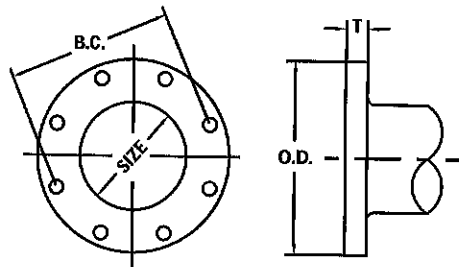

**FLANGE DETAILS**

NOM. SIZE	O.D.	B.C.	T	BOLT HOLE DIA.	BOLTS	
					SIZE	NO.
1	4.25	3.12	0.44	0.62	1/2 x 2	4
1 1/2	5.00	3.88	0.56	0.62	1/2 x 2	4
2	6.00	4.75	0.62	0.75	5/8 x 2 1/4	4
2 1/2	7.00	5.50	0.69	0.75	5/8 x 2 1/2	4
3	7.50	6.00	0.75	0.75	5/8 x 2 1/2	4
4	9.00	7.50	0.94	0.75	5/8 x 3	8
5	10.00	8.50	0.94	0.88	3/4 x 3	8
6	11.00	9.50	1.00	0.88	3/4 x 3 1/2	8
8	13.50	11.75	1.12	0.88	3/4 x 3 1/2	8
10	16.00	14.25	1.19	1.00	7/8 x 4	12
12	19.00	17.00	1.25	1.00	7/8 x 4	12
14	21.00	18.75	1.38	1.13	1 x 4 1/2	12
16	23.50	21.25	1.44	1.13	1 x 4 1/2	16
18	25.00	22.75	1.56	1.25	1 1/8 x 5	16
20	27.50	25.00	1.69	1.25	1 1/8 x 5	20
24	32.00	29.50	1.88	1.38	1 1/4 x 5 1/2	20
30	38.75	36.00	2.12	1.38	1 1/4 x 6 1/2	28
36	46.00	42.75	2.38	1.63	1 1/2 x 7	32
42	53.00	49.50	2.62	1.63	1 1/2 x 7 1/2	36
48	59.50	56.00	2.75	1.63	1 3/4 x 8	44
54	66.25	62.75	3.00	2.00	1 3/4 x 8 1/2	44
60	73.00	69.25	3.12	2.00	1 3/4 x 9	52
64	80.00	76.00	3.38	2.00	1 3/4 x 9	52

**SIZE RANGE (Please specify):**  
 Size Range \_\_\_\_\_

- LINING OPTIONS (Please check one):**
- Standard: Cement-lined and asphalt seal coat per ANSI/AWWA C104/A21.4 and UL/NSF-61
  - Optional: FBE (Fusion Bonded Epoxy) per ANSI/AWWA C116/A21.16 and UL/NSF-61 - ID & OD Only
  - Optional: P401 (Protecto 401) Ceramic Epoxy - sewer applications only. Not NSF-61
  - Optional: Other (specify) \_\_\_\_\_

- COATING OPTIONS (Please check one):**
- Standard: Red Prime Coat
  - Optional: Asphaltic seal coat per ANSI/AWWA C104/A21.4
  - Optional: FBE (Fusion Bonded Epoxy) per ANSI/AWWA C116/A21.16 and UL/NSF-61 - ID & OD Only
  - Optional: Other (specify) \_\_\_\_\_





Ductile Iron MJ Compact Fittings
ANSI/AWWA C153/A21.53

GENERAL SPECIFICATIONS

- MATERIAL: Ductile Iron per ASTM A536
PRESSURE: 350 PSI rating for 2" - 24" sizes, 250 PSI rating for 30" - 48" sizes and 150 PSI rating for 54" - 64" sizes
TESTING: In accordance with ANSI/AWWA C153/A21.53, ANSI/AWWA C111/A21.11, UL and FM requirements
LAYING LENGTH: In accordance with ANSI/AWWA C153/A21.53 (fittings not listed in ANSI/AWWA have dimensions per Star design as noted in the catalog)
DEFLECTION: 2"-4"=8° | 6"=7° | 8"-12"=5° | 14"-16"=3 1/2° | 18"-24"=3° | 30"-64"=2°
WEIGHTS: Are in pounds, unless noted otherwise and do not include accessories, cement lining and coating
FLANGES: Flanged ends on fittings match ANSI/AWWA C115/A21.15 and ANSI B16.1 class 125 flanges
CEMENT LINING: In accordance with ANSI/AWWA C104/A21.4 -- size 2" - 3" single thickness and sizes 4" - 64" double thickness
COATING: Asphaltic seal coat inside and out in accordance with ANSI/AWWA C104/A21.4 and referenced in ANSI/AWWA C153/A21.53
GASKETS: SBR in accordance with ANSI/AWWA C111/A21.11
T-BOLTS/NUTS: Low alloy steel in accordance with ANSI/AWWA C111/A21.11
APPROVALS: 3" - 12" UL/ULC Listed | 2" and greater are UL/ANSI/NSF Standards 61 and 372 | 3" - 16" FM APPROVED. Please consult factory for detail listing and approvals.
DIMENSIONS: All dimensions are in inches unless noted otherwise.
INSTALLATION: Per ANSI/AWWA C600 and C111 using DIP conforming to C150/C151 and PVC pipe conforming to C900/C905



SUBMITTAL INFORMATION
PROJECT NAME:
ENGINEER:
CONTRACTOR:
SPEC. SECTION:

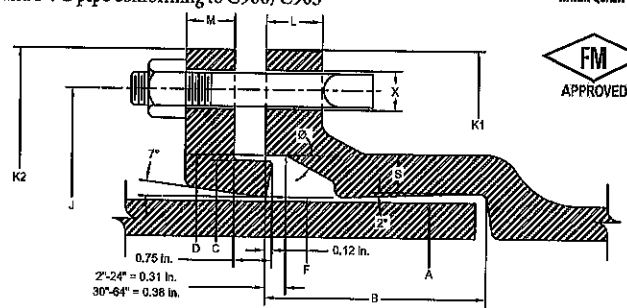

MECHANICAL JOINT DIMENSIONS

Table with 16 columns: NOM. SIZE, A DIA., B, C DIA., D DIA., F DIA., J DIA., K1 DIA., K2 DIA., L, M, S, Ø, X DIA., and BOLTS (SIZE, NO.). Rows range from size 2 to 64.

SIZE RANGE (Please specify):
Size Range

- LINING OPTIONS (Please check one):
[checked] Standard: Cement-lined and asphalt seal coat per ANSI/AWWA C104/A21.4 and UL/NSF-61
[ ] Optional: FBE (Fusion Bonded Epoxy) per ANSI/AWWA C116/A21.16 and UL/NSF-61-ID & OD Only
[ ] Optional: P401 (Protecto 401) Ceramic Epoxy-sewer applications only. Not NSF-61
[ ] Optional: Other (specify)

- COATING OPTIONS (Please check one):
[checked] Standard: Asphaltic seal coat per ANSI/AWWA C104/A21.4
[ ] Optional: FBE (Fusion Bonded Epoxy) per ANSI/AWWA C116/A21.16 and UL/NSF-61-ID & OD Only
[ ] Optional: Other (specify)



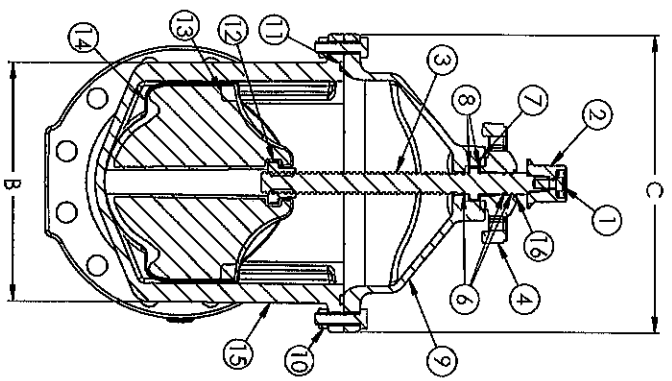

SECTION B-B  
SCALE 3 : 20

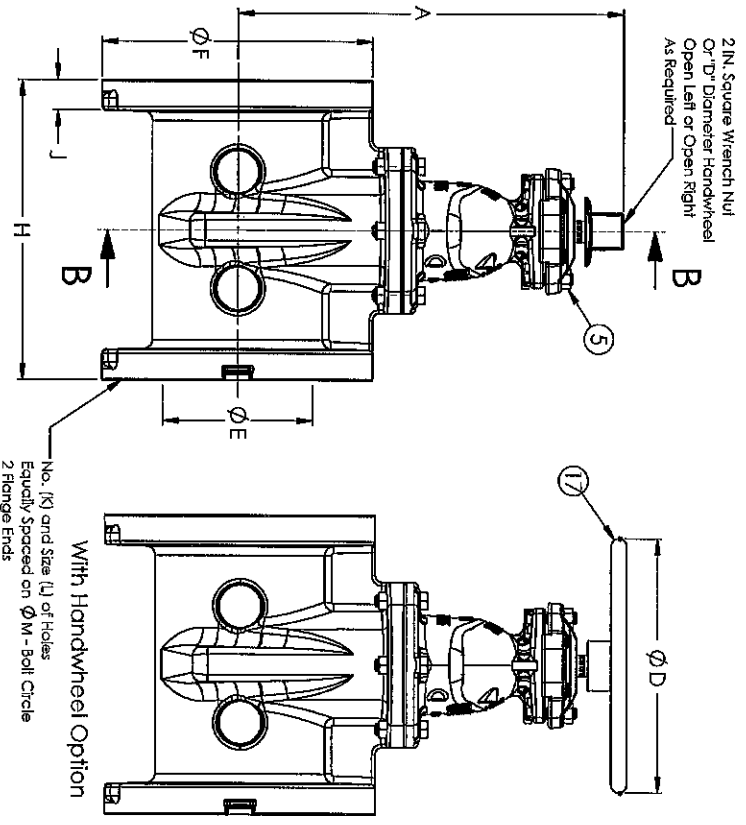

With Handwheel Option

ITEM NO.	DESCRIPTION	QTY	MATERIAL	ASTM	NOTES
1	Cap Screw	1	316 Stainless Steel	F593	Group 2-CW
2	Wrench Nut	1	Ductile Iron	A536	
3	Stem	1	Manganese Bronze	B138	Alloy C67600
4	Stuffing Box	1	Ductile Iron	A536	
5	Stuffing Box Bolts	2	316 Stainless Steel	F593 F564	Group 2-CW
6	O-Ring	3	Nitrile Rubber	D2000	
7	O-Ring	1	Nitrile Rubber	D2000	
8	Anti-Friction Washer	2	Acetal		
9	Bonnet	1	Ductile Iron	A536	
10	Bonnet Bolts	4	316 Stainless Steel	F593 F594	Group 2-CW
11	Bonnet O-Ring	1	Nitrile Rubber	D2000	
12	Disc Nut	1	Bronze	B594	
13	Encapsulated Disc	1	See Note 2		
14	Guide Cap	2	Acetal		
15	Body	1	Ductile Iron	A536	
16	Wiper Ring	1	Rubber		
17	Handwheel	1	Cast Iron (See Note 3)	A126	Class B

- Notes:
- Bronze Stem Options:
    - Manganese - ASTM B138 Alloy C67600
    - Everdur - ASTM B98 Alloy C66100
  - Rubber Encapsulated Ductile Iron Disc (ASTM A536)
    - SBR - ASTM D2000
    - EPDM - ASTM D2000
  - Manufacturer's Option to Upgrade Material to Ductile Iron ASTM A536 65-45-12 or 70-50-05

DIMENSIONS FOR RESILIENT WEDGE GATE VALVES - INCHES

Valve Size	A	B	C	D	E	F	G	H	J	K	L	M	Turns to Open
3	12.38	6.01	8.63	8.00	3.30	8.27	4	11.12	1.13	8	.88	6.614	11
4	14.19	8.25	10.79	11.00	4.30	10.00	4	12.00	1.25	8	.88	7.874	14
6	18.00	10.50	13.50	13.00	6.30	12.60	6	15.88	1.44	12	.88	10.630	20.5
8	21.50	13.21	16.36	14.00	8.30	14.96	6	16.50	1.63	12	1.13	12.972	26.5
10	25.50	16.48	19.79	16.00	10.30	17.52	8	18.00	1.87	16	1.25	15.236	33
12	28.62	19.83	21.00	16.00	12.30	20.47	8	19.75	2.00	16	1.25	17.756	38.5

**APPROVED**  
By MATTHEW SLIGER at 8:26 am, Sep 18, 2018

MUELLER CONFIDENTIAL  
TITLE TO AND OWNERSHIP OF THE ENGINEERING DATA REMAINS IN MUELLER CO. NO USE IS TO BE MADE OF THIS DATA EXCEPT AS SPECIFIED HEREIN. THIS IS PART OF THE RECEIPTS TO THESE CONDITIONS IS PRESUMED.

UNLESS OTHERWISE SPECIFIED: DIMENSIONS ARE IN INCHES TOLERANCES: FRACTIONS: ±.005, ±.010, ±.015, ±.020, ±.030, ±.040, ±.050, ±.060, ±.075, ±.100, ±.125, ±.150, ±.200, ±.250, ±.300, ±.375, ±.500, ±.625, ±.750, ±.875, ±.1.000, ±.1.250, ±.1.500, ±.2.000, ±.2.500, ±.3.000, ±.3.750, ±.5.000, ±.6.250, ±.7.500, ±.8.750, ±.10.000, ±.12.500, ±.15.000, ±.20.000, ±.25.000, ±.30.000, ±.37.500, ±.50.000, ±.62.500, ±.75.000, ±.87.500, ±.100.000, ±.125.000, ±.150.000, ±.200.000, ±.250.000, ±.300.000, ±.375.000, ±.500.000, ±.625.000, ±.750.000, ±.875.000, ±.1.000.000, ±.1.250.000, ±.1.500.000, ±.2.000.000, ±.2.500.000, ±.3.000.000, ±.3.750.000, ±.5.000.000, ±.6.250.000, ±.7.500.000, ±.8.750.000, ±.10.000.000, ±.12.500.000, ±.15.000.000, ±.20.000.000, ±.25.000.000, ±.30.000.000, ±.37.500.000, ±.50.000.000, ±.62.500.000, ±.75.000.000, ±.87.500.000, ±.100.000.000, ±.125.000.000, ±.150.000.000, ±.200.000.000, ±.250.000.000, ±.300.000.000, ±.375.000.000, ±.500.000.000, ±.625.000.000, ±.750.000.000, ±.875.000.000, ±.1.000.000.000, ±.1.250.000.000, ±.1.500.000.000, ±.2.000.000.000, ±.2.500.000.000, ±.3.000.000.000, ±.3.750.000.000, ±.5.000.000.000, ±.6.250.000.000, ±.7.500.000.000, ±.8.750.000.000, ±.10.000.000.000, ±.12.500.000.000, ±.15.000.000.000, ±.20.000.000.000, ±.25.000.000.000, ±.30.000.000.000, ±.37.500.000.000, ±.50.000.000.000, ±.62.500.000.000, ±.75.000.000.000, ±.87.500.000.000, ±.100.000.000.000, ±.125.000.000.000, ±.150.000.000.000, ±.200.000.000.000, ±.250.000.000.000, ±.300.000.000.000, ±.375.000.000.000, ±.500.000.000.000, ±.625.000.000.000, ±.750.000.000.000, ±.875.000.000.000, ±.1.000.000.000.000, ±.1.250.000.000.000, ±.1.500.000.000.000, ±.2.000.000.000.000, ±.2.500.000.000.000, ±.3.000.000.000.000, ±.3.750.000.000.000, ±.5.000.000.000.000, ±.6.250.000.000.000, ±.7.500.000.000.000, ±.8.750.000.000.000, ±.10.000.000.000.000, ±.12.500.000.000.000, ±.15.000.000.000.000, ±.20.000.000.000.000, ±.25.000.000.000.000, ±.30.000.000.000.000, ±.37.500.000.000.000, ±.50.000.000.000.000, ±.62.500.000.000.000, ±.75.000.000.000.000, ±.87.500.000.000.000, ±.100.000.000.000.000, ±.125.000.000.000.000, ±.150.000.000.000.000, ±.200.000.000.000.000, ±.250.000.000.000.000, ±.300.000.000.000.000, ±.375.000.000.000.000, ±.500.000.000.000.000, ±.625.000.000.000.000, ±.750.000.000.000.000, ±.875.000.000.000.000, ±.1.000.000.000.000.000, ±.1.250.000.000.000.000, ±.1.500.000.000.000.000, ±.2.000.000.000.000.000, ±.2.500.000.000.000.000, ±.3.000.000.000.000.000, ±.3.750.000.000.000.000, ±.5.000.000.000.000.000, ±.6.250.000.000.000.000, ±.7.500.000.000.000.000, ±.8.750.000.000.000.000, ±.10.000.000.000.000.000, ±.12.500.000.000.000.000, ±.15.000.000.000.000.000, ±.20.000.000.000.000.000, ±.25.000.000.000.000.000, ±.30.000.000.000.000.000, ±.37.500.000.000.000.000, ±.50.000.000.000.000.000, ±.62.500.000.000.000.000, ±.75.000.000.000.000.000, ±.87.500.000.000.000.000, ±.100.000.000.000.000.000, ±.125.000.000.000.000.000, ±.150.000.000.000.000.000, ±.200.000.000.000.000.000, ±.250.000.000.000.000.000, ±.300.000.000.000.000.000, ±.375.000.000.000.000.000, ±.500.000.000.000.000.000, ±.625.000.000.000.000.000, ±.750.000.000.000.000.000, ±.875.000.000.000.000.000, ±.1.000.000.000.000.000.000, ±.1.250.000.000.000.000.000, ±.1.500.000.000.000.000.000, ±.2.000.000.000.000.000.000, ±.2.500.000.000.000.000.000, ±.3.000.000.000.000.000.000, ±.3.750.000.000.000.000.000, ±.5.000.000.000.000.000.000, ±.6.250.000.000.000.000.000, ±.7.500.000.000.000.000.000, ±.8.750.000.000.000.000.000, ±.10.000.000.000.000.000.000, ±.12.500.000.000.000.000.000, ±.15.000.000.000.000.000.000, ±.20.000.000.000.000.000.000, ±.25.000.000.000.000.000.000, ±.30.000.000.000.000.000.000, ±.37.500.000.000.000.000.000, ±.50.000.000.000.000.000.000, ±.62.500.000.000.000.000.000, ±.75.000.000.000.000.000.000, ±.87.500.000.000.000.000.000, ±.100.000.000.000.000.000.000, ±.125.000.000.000.000.000.000, ±.150.000.000.000.000.000.000, ±.200.000.000.000.000.000.000, ±.250.000.000.000.000.000.000, ±.300.000.000.000.000.000.000, ±.375.000.000.000.000.000.000, ±.500.000.000.000.000.000.000, ±.625.000.000.000.000.000.000, ±.750.000.000.000.000.000.000, ±.875.000.000.000.000.000.000, ±.1.000.000.000.000.000.000.000, ±.1.250.000.000.000.000.000.000, ±.1.500.000.000.000.000.000.000, ±.2.000.000.000.000.000.000.000, ±.2.500.000.000.000.000.000.000, ±.3.000.000.000.000.000.000.000, ±.3.750.000.000.000.000.000.000, ±.5.000.000.000.000.000.000.000, ±.6.250.000.000.000.000.000.000, ±.7.500.000.000.000.000.000.000, ±.8.750.000.000.000.000.000.000, ±.10.000.000.000.000.000.000.000, ±.12.500.000.000.000.000.000.000, ±.15.000.000.000.000.000.000.000, ±.20.000.000.000.000.000.000.000, ±.25.000.000.000.000.000.000.000, ±.30.000.000.000.000.000.000.000, ±.37.500.000.000.000.000.000.000, ±.50.000.000.000.000.000.000.000, ±.62.500.000.000.000.000.000.000, ±.75.000.000.000.000.000.000.000, ±.87.500.000.000.000.000.000.000, ±.100.000.000.000.000.000.000.000, ±.125.000.000.000.000.000.000.000, ±.150.000.000.000.000.000.000.000, ±.200.000.000.000.000.000.000.000, ±.250.000.000.000.000.000.000.000, ±.300.000.000.000.000.000.000.000, ±.375.000.000.000.000.000.000.000, ±.500.000.000.000.000.000.000.000, ±.625.000.000.000.000.000.000.000, ±.750.000.000.000.000.000.000.000, ±.875.000.000.000.000.000.000.000, ±.1.000.000.000.000.000.000.000.000, ±.1.250.000.000.000.000.000.000.000, ±.1.500.000.000.000.000.000.000.000, ±.2.000.000.000.000.000.000.000.000, ±.2.500.000.000.000.000.000.000.000, ±.3.000.000.000.000.000.000.000.000, ±.3.750.000.000.000.000.000.000.000, ±.5.000.000.000.000.000.000.000.000, ±.6.250.000.000.000.000.000.000.000, ±.7.500.000.000.000.000.000.000.000, ±.8.750.000.000.000.000.000.000.000, ±.10.000.000.000.000.000.000.000.000, ±.12.500.000.000.000.000.000.000.000, ±.15.000.000.000.000.000.000.000.000, ±.20.000.000.000.000.000.000.000.000, ±.25.000.000.000.000.000.000.000.000, ±.30.000.000.000.000.000.000.000.000, ±.37.500.000.000.000.000.000.000.000, ±.50.000.000.000.000.000.000.000.000, ±.62.500.000.000.000.000.000.000.000, ±.75.000.000.000.000.000.000.000.000, ±.87.500.000.000.000.000.000.000.000, ±.100.000.000.000.000.000.000.000.000, ±.125.000.000.000.000.000.000.000.000, ±.150.000.000.000.000.000.000.000.000, ±.200.000.000.000.000.000.000.000.000, ±.250.000.000.000.000.000.000.000.000, ±.300.000.000.000.000.000.000.000.000, ±.375.000.000.000.000.000.000.000.000, ±.500.000.000.000.000.000.000.000.000, ±.625.000.000.000.000.000.000.000.000, ±.750.000.000.000.000.000.000.000.000, ±.875.000.000.000.000.000.000.000.000, ±.1.000.000.000.000.000.000.000.000.000, ±.1.250.000.000.000.000.000.000.000.000, ±.1.500.000.000.000.000.000.000.000.000, ±.2.000.000.000.000.000.000.000.000.000, ±.2.500.000.000.000.000.000.000.000.000, ±.3.000.000.000.000.000.000.000.000.000, ±.3.750.000.000.000.000.000.000.000.000, ±.5.000.000.000.000.000.000.000.000.000, ±.6.250.000.000.000.000.000.000.000.000, ±.7.500.000.000.000.000.000.000.000.000, ±.8.750.000.000.000.000.000.000.000.000, ±.10.000.000.000.000.000.000.000.000.000, ±.12.500.000.000.000.000.000.000.000.000, ±.15.000.000.000.000.000.000.000.000.000, ±.20.000.000.000.000.000.000.000.000.000, ±.25.000.000.000.000.000.000.000.000.000, ±.30.000.000.000.000.000.000.000.000.000, ±.37.500.000.000.000.000.000.000.000.000, ±.50.000.000.000.000.000.000.000.000.000, ±.62.500.000.000.000.000.000.000.000.000, ±.75.000.000.000.000.000.000.000.000.000, ±.87.500.000.000.000.000.000.000.000.000, ±.100.000.000.000.000.000.000.000.000.000, ±.125.000.000.000.000.000.000.000.000.000, ±.150.000.000.000.000.000.000.000.000.000, ±.200.000.000.000.000.000.000.000.000.000, ±.250.000.000.000.000.000.000.000.000.000, ±.300.000.000.000.000.000.000.000.000.000, ±.375.000.000.000.000.000.000.000.000.000, ±.500.000.000.000.000.000.000.000.000.000, ±.625.000.000.000.000.000.000.000.000.000, ±.750.000.000.000.000.000.000.000.000.000, ±.875.000.000.000.000.000.000.000.000.000, ±.1.000.000.000.000.000.000.000.000.000.000, ±.1.250.000.000.000.000.000.000.000.000.000, ±.1.500.000.000.000.000.000.000.000.000.000, ±.2.000.000.000.000.000.000.000.000.000.000, ±.2.500.000.000.000.000.000.000.000.000.000, ±.3.000.000.000.000.000.000.000.000.000.000, ±.3.750.000.000.000.000.000.000.000.000.000, ±.5.000.000.000.000.000.000.000.000.000.000, ±.6.250.000.000.000.000.000.000.000.000.000.000, ±.7.500.000.000.000.000.000.000.000.000.000.000, ±.8.750.000.000.000.000.000.000.000.000.000.000, ±.10.000.000.000.000.000.000.000.000.000.000.000, ±.12.500.000.000.000.000.000.000.000.000.000.000, ±.15.000.000.000.000.000.000.000.000.000.000.000, ±.20.000.000.000.000.000.000.000.000.000.000.000, ±.25.000.000.000.000.000.000.000.000.000.000.000, ±.30.000.000.000.000.000.000.000.000.000.000.000, ±.37.500.000.000.000.000.000.000.000.000.000.000, ±.50.000.000.000.000.000.000.000.000.000.000.000, ±.62.500.000.000.000.000.000.000.000.000.000.000.000, ±.75.000.000.000.000.000.000.000.000.000.000.000.000, ±.87.500.000.000.000.000.000.000.000.000.000.000.000, ±.100.000.000.000.000.000.000.000.000.000.000.000.000, ±.125.000.000.000.000.000.000.000.000.000.000.000.000, ±.150.000.000.000.000.000.000.000.000.000.000.000.000, ±.200.000.000.000.000.000.000.000.000.000.000.000.000, ±.250.000.000.000.000.000.000.000.000.000.000.000.000, ±.300.000.000.000.000.000.000.000.000.000.000.000.000, ±.375.000.000.000.000.000.000.000.000.000.000.000.000, ±.500.000.000.000.000.000.000.000.000.000.000.000.000, ±.625.000.000.000.000.000.000.000.000.000.000.000.000.000, ±.750.000.000.000.000.000.000.000.000.000.000.000.000.000, ±.875.000.000.000.000.000.000.000.000.000.000.000.000.000, ±.1.000.000.000.000.000.000.000.000.000.000.000.000.000.000, ±.1.250.000.000.000.000.000.000.000.000.000.000.000.000.000, ±.1.500.000.000.000.000.000.000.000.000.000.000.000.000.000, ±.2.000.000.000.000.000.000.000.000.000.000.000.000.000.000, ±.2.500.000.000.000.000.000.000.000.000.000.000.000.000.000, ±.3

**CLOW**  
VALVE CO.

ClowValve.com

**RESILIENT  
WEDGE GATE  
VALVES**

**4" THROUGH 20"  
MODEL 2638**

AWWA C515 250 PSI • UL/FM APPROVED 200 PSI • NSF  
61 CERTIFIED • FULL WATER WAY • FUSION BONDED  
EPOXY COATED • 10 YEAR LIMITED WARRANTY



Clow Valve, A Division of McWane, Inc.

**For Generations**

# RESILIENT WEDGE VALVE

In 1975, Clow recognized the increased requirements and escalating maintenance cost of water systems in the United States.

Clow responded by introducing the first R/W (Resilient Wedge) Gate Valve in America. This introduction revolutionized the valve market in the U.S.

Clow was the first to introduce and still leads in the design and technical development of the bubble-tight resilient seating valve.

The Clow Resilient Wedge Valve, with its unique features and benefits, was the first to be manufactured with both AWWA and UL/FM approval for all water system requirements.

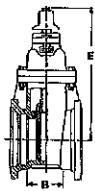

**F-6100**  
MECHANICAL JOINT  
4" - 20"

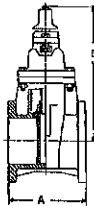

**F-6102**  
FLANGED  
4" - 20"

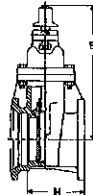

**F-6106**  
FLANGED X MECHANICAL JOINT  
4" - 20"

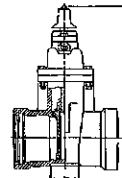

**F-6110**  
PUSH ON FOR SDR PVC  
4" - 12"

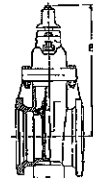

**F-6111**  
MECHANICAL CUTTING IN JOINT  
4" - 12"

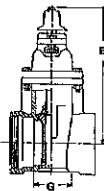

**F-6112**  
TYTON ENDS FOR D.I. AND C900 PVC PIPE  
4" - 16"

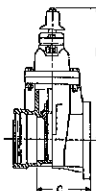

**F-6113**  
FLANGED X TYTON  
4" - 12"

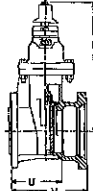

**F-6114**  
MECHANICAL JOINT FOR TAPPING  
4" - 20"

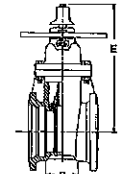

**F-6120**  
MECHANICAL JOINT POST INDICATOR VALVE  
4" - 16"

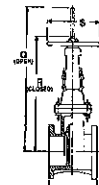

**F-6136**  
FLANGED OS&Y  
4" - 16"

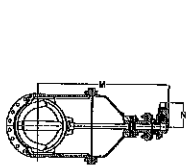

**BEVEL GEARING**  
HORIZONTAL INSTALLATION  
ALL END STYLES  
14" - 20"

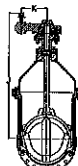

**SPUR GEARING**  
VERTICAL INSTALLATION  
ALL END STYLES  
14" - 20"

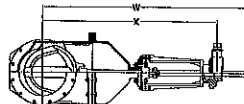

**OS&Y BEVEL GEARING**  
HORIZONTAL INSTALLATION  
ALL END STYLES  
14" - 20"

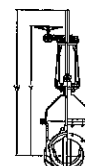

**OS&Y SPUR GEARING**  
VERTICAL INSTALLATION  
ALL END STYLES  
14" - 20"

VALVE SIZE	A	B	C	E	G	H	J	K	M	N	P	Q	R	S	U	V	NO GEAR*	GEARED*	W	X	Y
4"	9	4-1/2	6-3/4	14-3/4	4-5/8	6-3/4	-	-	-	-	4-1/2	22-3/4	18-1/4	10	6-3/4	9-1/4	13-1/2	-	-	-	-
6"	10-1/2	5-1/2	7-7/8	19	5-1/4	8	-	-	-	-	5	30-1/8	23-3/4	12	8	10-1/2	19-1/2	-	-	-	-
8"	11-1/2	8-1/8	8-1/2	22-1/2	5-5/8	9-3/4	-	-	-	-	5-1/2	37-3/4	29-1/4	14	10-3/4	13-1/4	25-1/2	-	-	-	-
10"	13	10-1/2	10	28-1/2	7	11-3/4	-	-	-	-	7	45-3/4	35-3/8	18	11-3/4	14-7/8	31-1/2	-	-	-	-
12"	14	10-3/4	11-1/4	30	8-1/2	12-7/8	-	-	-	-	8-1/2	53-1/8	40-3/8	18	12-3/8	15	37-3/4	-	-	-	-
14"	15	10	-	37-3/4	10-1/2	13-1/2	52-1/8	8	48-5/8	9-1/8	-	74-3/4	59-3/4	22	13-1/4	16-3/4	52	100	76	59-7/8	64-1/2
16"	16	10	-	37-3/4	10-1/2	13	51-1/8	8	47-5/8	9-1/8	-	74-3/4	59-3/4	22	12-3/4	16-1/4	52	100	76	59-7/8	64-1/2
18"	17	11-3/4	-	-	-	14-7/8	58	12	55-3/4	10-1/8	-	-	-	-	14-5/8	18-1/8	-	189	90-7/8	70-1/8	74-5/8
20"	18	11	-	-	-	14-1/2	57	12	54-3/4	10-1/8	-	-	-	-	14-1/2	18	-	189	90-7/8	70-1/8	74-5/8

**NOTE:** It is recommended that valves be installed with stems vertical when used in raw sewage, or sludge applications, or in water with excessive sediment. Flanged end connections are not recommended for buried service. \* No. of turns to full open

## RECOMMENDED SPECIFICATIONS

1. Valves shall conform to the latest revision of AWWA Standard C515 covering resilient seated gate valves for water supply service.
2. The valves shall have a ductile iron body, bonnet, and O-ring plate. The wedge shall be totally encapsulated with rubber.
3. The sealing rubber shall be permanently bonded to the wedge per ASTM D429.
4. Valves shall be supplied with O-ring seals at all pressure retaining joints. No flat gaskets shall be allowed.
5. The valves shall be either non-rising stem or rising stem, opening by turning left or right, and provided with 2" square operating nut or a handwheel with the word "Open" and an arrow to indicate the direction to open.
6. Stems shall be cast copper alloy with integral collars in full compliance with AWWA. All stems shall operate with copper alloy stem nuts independent of wedge and of stem (in NRS valves).
7. Stems shall have two O-rings located above thrust collar and one O-ring below. Stem O-rings shall be replaceable with valve fully opened and subjected to full pressure. The stems on 4" – 20" shall also have two low torque thrust bearings located above and below the stem collar to reduce friction during operation.
8. Waterway shall be smooth, unobstructed and free of all pockets, cavities and depressions in the seat area. Valves 4" and larger shall accept a full size tapping cutter.
9. The body, bonnet and O-ring plate shall be fusion-bonded epoxy coated, both interior and exterior on body and bonnet. Epoxy shall be applied in accordance with AWWA C550 and be NSF 61 Certified.
10. Each valve shall have maker's name, pressure rating, country of origin, and year in which it was manufactured cast in the body. Prior to shipment from the factory, each valve shall be tested by hydrostatic pressure equal to the requirements of AWWA C515 (and UL/FM where applicable).
11. Valves shall have all component parts cast and assembled in the USA and shall be manufactured by the Clow Valve Company.

## COMMITTED TO ENVIRONMENTAL RESPONSIBILITY

Clow Valve Company is committed to protecting our natural resources through environmentally responsible manufacturing practices, including the use of 80+% recycled content in our hydrants and valves.



**CLOW**  
VALVE CO.

902 South 2nd Street  
Oskaloosa, IA 52577  
Ph 641-673-8611  
Fx 641-673-8289



**POCKET ENGINEER**  
Available for iOS + Android  
or online at [pe.mcwane.com](http://pe.mcwane.com).



\*PATENT PENDING  
REVISION B-2022



[ClowValve.com](http://ClowValve.com)



PVC Stargrip® series 4000

Mechanical Joint Wedge Action Restraint for Plastic Pressure Pipe

Sizes 3" - 48"

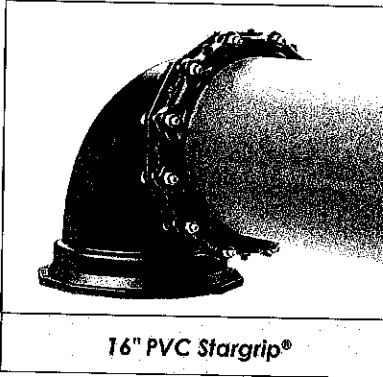

16" PVC Stargrip®

SUBMITTAL INFORMATION

PROJECT NAME: [ ]

ENGINEER: [ ]

CONTRACTOR: [ ]

SPEC. SECTION: [ ]



FEATURES & ADVANTAGES

- Sizes 3" - 12" consists of G2 design.
- Can be used on 4"-48" AWWA C900 PVC, 4"-18" AWWA C909 PVCO and AWWA C906 HDPE pipes along with 3"-12" IPS OD\* ASTM D2241 PVC pipe. (\*A transition gasket is required on IPS Plastic Pipe). See Tables A and B for further details.
- Sizes 4"-12" are listed with Underwriters Laboratories, approved by Factory Mutual Research, and tested to and meets the requirements of ASTM F1674.
- Safety factor is twice (2:1) the standardized pressure rating listed in Tables A and B.
- Offers 5° of deflection on 3"-12" AWWA C900, 3° on 14"-24", 2° on 30"-36" and 1° on 42"-48".
- Standard gland color is Coral Red and is made from high strength Ductile Iron per ASTM A536 Grade 65-45-12 and is compatible with all Mechanical Joints that conform to ANSI/AWWA C111/A21.11.
- Eliminates the need for tie rods and thrust blocks.
- Fewer wedges and lower wedge-bolt torque results in quicker and easier installation (see specifications and tables C, D & E).
- Sizes 4"-12" uses a spacer that is easily removed when restraint is used on IPS Plastic pipe.
- Curved wedges reduce the amount of localized pipe deformation.
- The gland's larger inside diameter allows restraint to be installed on pipe with more ovality.
- Improved design of the wedge bolts prevents over torquing which can damage PVC pipe.
- For sizes 3"-12" and 42"-48" wedges are mechanically attached to wedge bolts, which eliminates the possibility of falling out during shipping and handling.
- US Patent# 9,822,910 applies to sizes 3"-12" and 42"-48".

MATERIAL SPECIFICATIONS:

- Wedges: Ductile Iron per ASTM A536, Grade 65-45-12. Wedge coating is a thermally cured fluoropolymer epoxy.

GLAND FINISH OPTIONS (Please check one):

- Standard: alkyd enamel coating
- Optional: Starbond™ TGIC polyester powder coating applied by an electrostatic spray process
- Optional: Other (specify) \_\_\_\_\_

COUNTRY OF ORIGIN OPTION (Please check one):

- Import
- Domestic - AIS Compliant

HARDWARE OPTIONS (Please check):

- Standard: T-bolts and nuts are high strength low alloy steel manufactured in accordance with ANSI/AWWA C111/A21.11
- Optional: T-bolts alloy SS 304 per ASTM F593; Nuts alloy SS 304 per ASTM F594 CW
- Optional: T-bolts SS 316 per ASTM F593; Nuts SS 316 per ASTM A194 Grade 8M
- Optional: T-bolts and nuts Fluoropolymer Star-Blue coated high strength low alloy steel manufactured in accordance with ANSI/AWWA C111/A21.11

STAR® PIPE PRODUCTS

REV.2501



® REGISTERED TRADEMARK OF STAR PIPE PRODUCTS



# PVC Stargrip® series 4000

Mechanical Joint Wedge Action Restraint  
for Plastic Pressure Pipe  
Sizes 3" - 48"

## TECHNICAL INFORMATION (SIZES 3"-12")

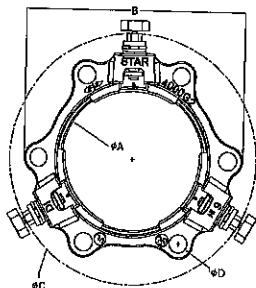

PVC STARGRIP® 4000 SPECIFICATIONS* (SIZES 3"-12")									
NOM. SIZE	C900/C909 PIPE CI OD	IPS PIPE OD¹	ØA	B	ØC²	ØD	T-BOLT SIZE (QTY)	WEDGE (QTY)	APPROX WT. (LBS)
<input type="checkbox"/> 3	N/A	3.50	4.09	7.57	9.11	¾	¾ x 3 (4)	2	6
<input type="checkbox"/> 4	4.80	4.50	4.93	9.00	10.44	¾	¾ x 3 ½ (4)	2	7
<input type="checkbox"/> 6	6.90	6.63	7.03	11.00	12.54	¾	¾ x 3 ½ (6)	3	10
<input type="checkbox"/> 8	9.05	8.63	9.18	13.25	14.59	¾	¾ x 4 (6)	4	15
<input type="checkbox"/> 10	11.10	10.75	11.23	15.62	16.74	¾	¾ x 4 (8)	6	21
<input type="checkbox"/> 12	13.20	12.75	13.33	17.87	18.69	¾	¾ x 4 (8)	6	25

\*All dimensions in inches except where indicated.  
1 - transition gasket required  
2 - dimension after assembly on pipe

## TECHNICAL INFORMATION (SIZES 14"-36")

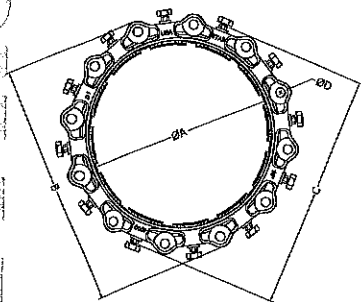

PVC STARGRIP® 4000 SPECIFICATIONS* (SIZES 14"-36")									
NOM. SIZE	C900/C909 PIPE CI OD	ØA	B	ØC²	ØD	T-BOLT SIZE (QTY)	WEDGE (QTY)	APPROX WT. (LBS)	
<input type="checkbox"/> 14	15.30	15.45	20.75	20.48	¾	¾ x 4 ½ (10)	10	50	
<input type="checkbox"/> 16	17.40	17.55	23.00	22.58	¾	¾ x 4 ½ (12)	12	60	
<input type="checkbox"/> 18	19.50	19.65	25.25	24.68	¾	¾ x 4 ½ (12)	12	65	
<input type="checkbox"/> 20	21.60	21.75	27.50	26.78	¾	¾ x 4 ½ (14)	14	76	
<input type="checkbox"/> 24	25.80	25.95	32.00	30.98	¾	¾ x 5 (16)	16	98	
<input type="checkbox"/> 30	32.00	32.18	39.38	36.94	1-½	1 x 6 (20)	20	173	
<input type="checkbox"/> 36	38.30	38.48	46.25	43.24	1-½	1 x 6 (24)	24	219	

\*All dimensions in inches except where indicated.  
2 - dimension after assembly on pipe

## TECHNICAL INFORMATION (SIZES 42"-48")

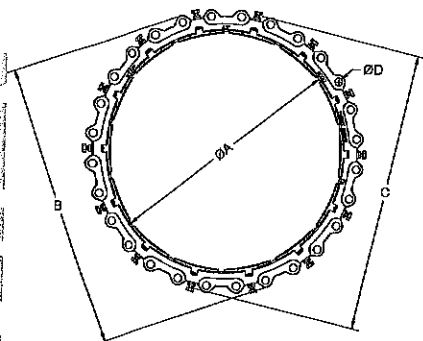

PVC STARGRIP® 4000 SPECIFICATIONS* (SIZES 42"-48")									
NOM. SIZE	C900/C909 PIPE CI OD	ØA	B	ØC²	ØD	T-BOLT SIZE (QTY)	WEDGE (QTY)	APPROX WT. (LBS)	
<input type="checkbox"/> 42	44.50	44.75	53.12	52.58	1-¾	1 ¼ x 8 ½ (28)	14	436	
<input type="checkbox"/> 48	50.80	51.05	60.00	58.88	1-¾	1 ¼ x 8 ½ (32)	16	530	

\*All dimensions in inches except where indicated.  
2 - dimension after assembly on pipe

STAR PIPE PRODUCTS



Phone: (800) 976-BOLT  
 Web: itpbolt.com  
 Email: sales@itpbolt.com  
 Email: purchasing@itpbolt.com

BREA  
 FRESNO  
 RANCHO CUCAMONGA  
 UNION CITY

# HEX BOLTS A307 GRADE A

SUBMITTAL SPECIFICATIONS  
 ABSTRACT OF ASTM A307 GRADE A

GRADE: Low Carbon Steel 60,000 PSI

## CHEMICAL REQUIREMENTS

Chemical analysis shall be performed in accordance with ASTM A751

CARBON MAX	MANGANESE MAX	PHOPHOROUS MAX	SULFER MAX
0.29	1.20	0.04	0.15

## MECHANICAL REQUIREMENTS

HARDNESS BRINEL		HARDNESS ROCKWELL		TENSILE STRENGTH (KSI)		ELONGATION IN 2 IN (50MM)
MIN	MAX	MIN	MAX	MIN	MAX	MIN
121	241	69	100	60	-	18

Hex Nuts ASTM A563 (ASME B18.2.2)       Heavy Hex Nuts ASTM A563 (ASME B18.2.2)

Washers ASTM F844-04 (ASME B18.22.1)

## BOLTS AND NUTS MAY BE SUPPLIED

Plain     Zinc Plated per ASTM B633     Hot Dip Galvanized Per ASTM A153     Cadmium Plated

## LOCATION

Buried     Submerged     Above Grade     Below Grade     Other

**DIMENSIONAL DATA:** Unless otherwise specified in the purchase order, parts shall be the coarse threaded series as specified in the latest issue of ANSI / ASME B1.1, page A-26. Having a 2A tolerance. Grade A Bolts shall have Hex Bolt Dimensions as given in the latest issue of ANSI / ASME B 18.2.1, Page C1. Unless otherwise specified Grade A Bolts should be used with Hex Nuts.

**ADDITINOAL INFORMATION:** Additional information can be found in ASTM A307A-07B, ASTM A563-04A



# Star-Tite™ Flanged Gasket

3" to 36", Ring Style

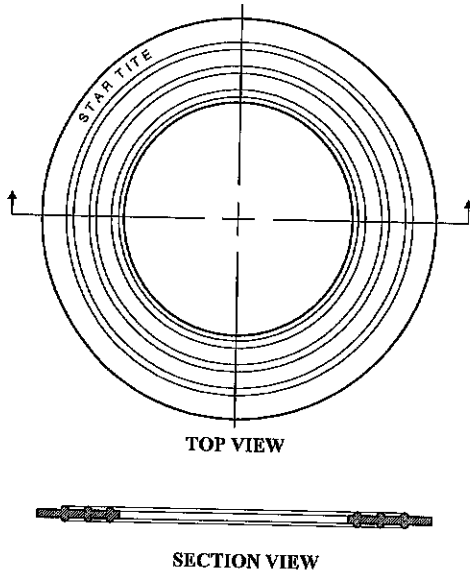

## INTRODUCTION

Historically, flat red rubber gaskets have been used for sealing flanged joints. These gaskets may not have NSF/ANSI 61 or NSF/ANSI 372 certification and do not qualify for higher ratings in standards such as ANSI/AWWA C110/A21.10. The Star-Tite™ flanged gasket is a specially designed gasket that qualifies for the higher rating. It also is listed by UL as satisfying both NSF/ANSI 61 and NSF/ANSI 372 requirements for potability.



## LOWER TORQUE

The Star-Tite™ Ring Gasket has about one half the area to compress when compared to a full face gasket, which results in a reduction of the torque required to achieve a proper seal. In addition, the Star-Tite™ Ring Gasket incorporates three bulbs that are molded into the gasket, a geometry that improves the performance when compared to a typical flat full face red rubber gasket.

## HIGHER PERFORMANCE

AWWA standard ANSI/AWWA C110/A21.10 describes specially designed gaskets as follows:

**Also available for most sizes are specially designed gaskets, either ring or full-face, using one or more annular rings molded into the gasket to improve the gasket performance.**

**Appendix A, Section A.2, Gaskets**

Footnotes below the pressure rating tables in ANSI/AWWA C110/A21.10 for flanged fittings allow the rating of flanged fittings that use these special gaskets to be 350 psi in sizes 24-inch and less. The Star-Tite™ gasket qualifies as one of these special gasket designs. When normal flat full face red rubber gaskets are used, the rating is 250 psi.

The bulb type rings on the Star-Tite™ ring gasket allow the gasket material to compress in three localized areas of the flange. The inner bulb is located inside the tapered pipe thread that is typical with fabricated pipe. This creates a pressure boundary that prevents leakage through the threaded connection, which is shown in Figure 1 on the next page. The outer two bulbs better accommodate minor misalignment that occasionally occurs when flat surfaces are mated together.

STAR® PIPE PRODUCTS



# Star-Tite™ Flanged Gasket

3" to 36", Ring Style

## TECHNICAL INFORMATION

Figure 1.

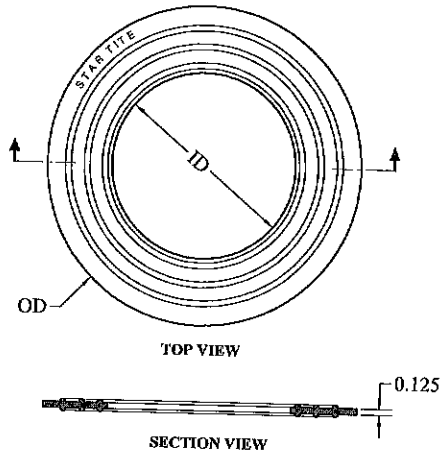
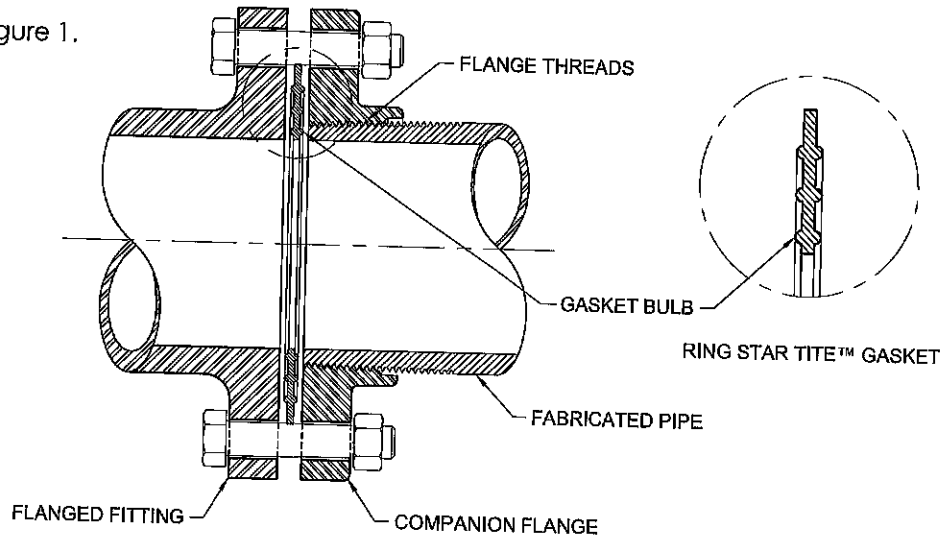

Table 1 - FLANGE ACCESSORY PACKS C111/A.21,11\*

NOM. SIZE	ID	OD	BOLTS	BOLTS (QTY)	MAX PRESSURE RATING (PSI)	BOLT TORQUE (FT-LB)	APPROX. WT. (LBS)
3	3.000	5.375	3/8 x 2 1/2	4	350	110	2
4	4.000	6.875	3/8 x 3	8	350	110	4
6	6.000	8.750	3/4 x 3 1/2	8	350	110	5
8	8.000	11.000	3/4 x 3 1/2	8	350	110	5
10	10.000	13.375	7/8 x 4	12	350	130	12
12	12.000	16.125	7/8 x 4	12	350	130	13
14	14.000	17.750	1 x 4 1/2	12	350	150	19
16	16.000	20.250	1 x 4 1/2	16	350	160	25
18	18.000	21.625	1 1/8 x 5	16	350	180	36
20	20.000	23.875	1 1/8 x 5	20	350	200	45
24	24.000	28.250	1 1/4 x 5 1/2	20	350	220	61
30	30.000	34.750	1 1/4 x 6 1/2	28	250	140	94
36	36.000	41.250	1 1/2 x 7	32	250	160	172

\*All dimensions in inches except where indicated.

## GENERAL SPECIFICATIONS

- HEX BOLTS:** Per ANSI/ASME B18.2.1 - Material per ASTM A307 Grade B, Zinc Plated
- HEX NUTS:** Per ANSI/ASME B18.2.2 - Material per ASTM A563 Grade A or B, Zinc Plated
- GASKET MATERIAL:** Vulcanized Styrene Butadiene Rubber (SBR)
- DIMENSIONS:** Refer to Table 1 above or FAH03-36RG submittal drawing number A6531.
- CERTIFICATIONS:** UL listed to NSF/ANSI 61 and NSF/ANSI 372 for potability.
- PRESSURE RATING:** 350 psi for sizes 3" to 24"; 250 psi for sizes 30" to 36".

STAR PIPE PRODUCTS

# HYMAX<sup>®</sup>

a **MUELLER** brand

## HYMAX<sup>®</sup> 2 COUPLING (1.5" - 12")

### Product Specifications

#### FEATURES

- Advanced wide-range coupling with a patented flip gasket.
- Eliminates gasket removal mistakes and maximizes installer work efficiency.
- Only 2 - 4 top facing bolts, for faster and safer installation.
- Ready-to-use design to eliminate extensive under-pipe digging.
- Allows 4° dynamic deflection on each end, reducing future pipe damage.
- Patented hydraulically-assisted gasket with 2-stage sealing.
- Suitable for many types of pipe.
- One product can connect pipes of two different materials.
- Based on the game-changing HYMAX that has been field-proven in millions of installations in the US.
- Product performance, OD range and pressures are identical to those of the original HYMAX.
- Lifting T-handle only on 3"-12".

#### SPECIFICATIONS STANDARDS

- HYMAX2 meets or exceeds standards AWWA C219, NSF 61, NSF 372.

#### SIZE

- Available in nominal diameter from 1.5" - 12" standard.

#### MATERIALS

##### END RINGS

- ASTM A283/A283M Grade C steel.



JOIN



REPAIR



RESTRAIN



TAP

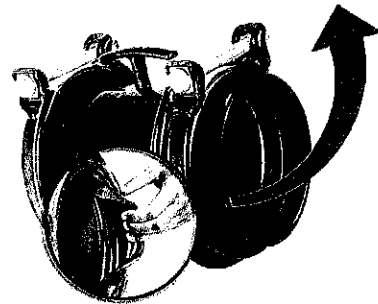

##### CENTER RING

- ASTM A53 Grade A steel.

##### GASKETS

- EPDM compounded for water and sewage in accordance with ASTM D2000, meets international standards for contact with drinking water.

##### BRIDGE

- Available in AISI 304 or 316 Stainless Steel, ASTM A240.

##### SPHERICAL SPACERS

- Available in AISI 304 (ASTM A351 CF8) or SS316 (ASTM A351 CF8M) Stainless Steel.

##### COATING

- 100% fusion bonded epoxy for enhanced corrosion protection.
- Average thickness 14 mm.

##### BOLTS, NUTS & WASHERS

- Available in AISI 304 or SS316 stainless steel. Rolled thread and anti-galling coating. ASTM F593, ASTM F594 and ASTM A240 respectively.

**MUELLER**

## **PRODUCT PERFORMANCE**

### **WORKING TEMPERATURE**

- -20°F up to +125°F

### **DYNAMIC DEFLECTION**

- Up to 4° per side

### **MIN. PIPE INSERTION**

- 2.25"

### **MAXIMUM OFFSET FOR MISALIGNED PIPES**

- ND 1.5" - ND 3": 0.39"
- ND 4" - ND 12": 0.51"

### **MAXIMUM OUT OF ROUNDNESS**

- ND 1.5": 0.08"
- ND 2" - ND 3": 0.20"
- ND 4" - ND 12": 0.31"

### **WORKING PRESSURE**

- 260 psi

### **VACUUM TEST**

- 12 psi

# PRODUCT TABLES

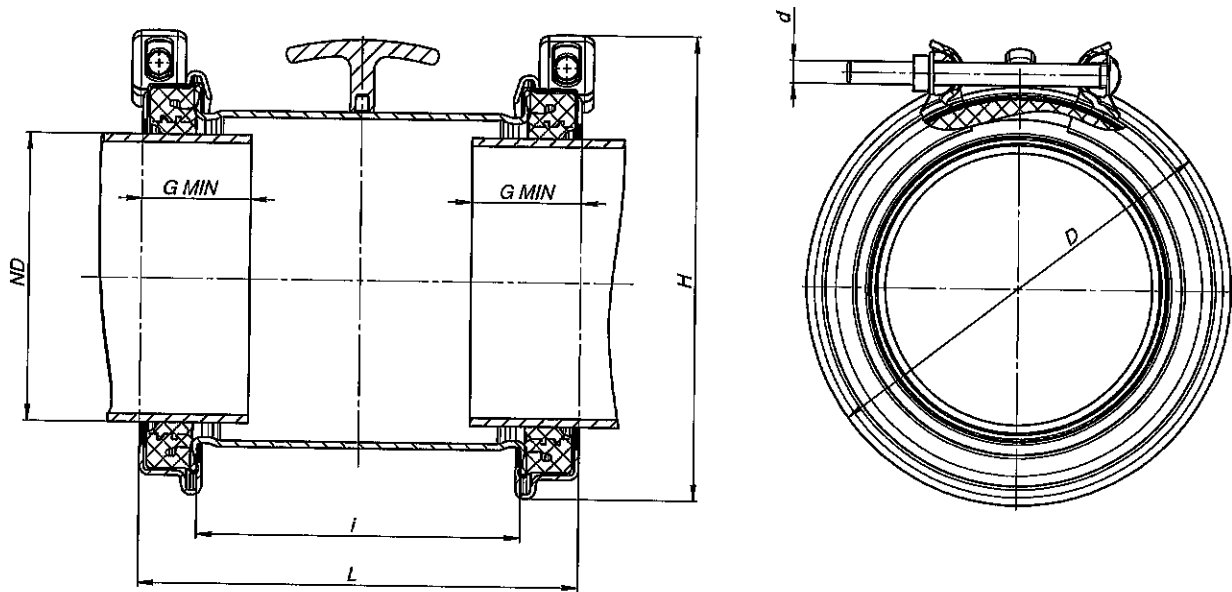

## HYMAX<sup>®</sup> 2 NOMINAL SIZES 1.5" - 12"

HYMAX Part Number	ND (inch)	Overall Range (inch)	Range in Closed Gasket Position (inch)	Range in Open Gasket Position (inch)	Bolts Qty.-Size (mm)	Torque (ft-lbs)	Approx. Weight (lbs)	Length (inch)
860-XX-0041-16	1.5	1.61 - 2.13	1.61 - 1.97	1.96 - 2.13	2 - M12	35	5	6.1
860-XX-0054-16	2	2.10 - 3.03	2.10 - 2.60	2.56 - 3.03	2 - M12	50	7.5	6.8
860-XX-0088-16	3	3.46 - 4.33	3.46 - 3.90	3.86 - 4.33	2 - M12	50	10.8	8.8
860-XX-0108-16	4	4.25 - 5.63	4.25 - 5.00	4.92 - 5.63	2 - M14	75	15	8.8
860-XX-0130-16	5	5.12 - 6.38	5.12 - 5.75	5.71 - 6.38	2 - M14	75	19	10.8
860-XX-0163-16	6	6.42 - 7.68	6.42 - 7.05	7.01 - 7.68	2 - M14	75	23	10.8
860-XX-0190-16	7	7.48 - 8.74	7.48 - 8.11	8.07 - 8.74	2 - M14	75	24	10.8
860-XX-0217-16	8	8.54 - 9.84	8.54 - 9.17	9.13 - 9.84	2 - M14	75	28	10.8
860-XX-0272-16	10	10.70 - 12.00	10.70 - 11.37	11.33 - 12.00	2 - M14	75	32	10.8
860-XX-0278-16	10	10.96 - 12.26	10.96 - 11.63	11.59 - 12.26	2 - M14	75	33	10.8
860-XX-0315-16	12	12.40 - 13.66	12.40 - 13.03	12.99 - 13.66	2 - M14	80	39	10.8
860-XX-0334-16	12	13.15 - 14.41	13.15 - 13.78	13.74 - 14.41	2 - M14	80	39	10.8

When XX = 54 - Fasteners are AISI 304SS

When XX = 94 - Fasteners are AISI 316SS

For specific sizes of products in stock, call Mueller for details.

To learn more, visit [HymaxUSA.com](http://HymaxUSA.com).

Mueller refers to one or more of Mueller Water Products, Inc., a Delaware corporation ("MWP"), and its subsidiaries. MWP and each of its subsidiaries are legally separate and independent entities when providing products and services. MWP does not provide products or services to third parties. MWP and each of its subsidiaries are liable only for their own acts and omissions and not those of each other. MWP brands include Mueller<sup>®</sup>, Echologics<sup>®</sup>, Hydro Gate<sup>®</sup>, Hydro-Guard<sup>®</sup>, HYMAX<sup>®</sup>, Krausz<sup>®</sup>, Jones<sup>®</sup>, Mi.Net<sup>®</sup>, Milliken<sup>®</sup>, Pratt<sup>®</sup>, Pratt Industrial<sup>®</sup>, Sentry<sup>™</sup>, Singer<sup>®</sup>, and U.S. Pipe Valve & Hydrant. Please see [muellerwp.com/brands](http://muellerwp.com/brands) to learn more.

© 2023 Mueller Co., LLC. All Rights Reserved. The trademarks, logos and service marks displayed in this document are the property of Mueller Co., LLC, its affiliates or other third parties. Products above marked with a section symbol (S) are subject to patents or patent applications. For details, visit [www.mwppat.com](http://www.mwppat.com). These products are intended for use in potable water applications. Please contact your HYMAX Sales or Customer Service Representative concerning any other application(s).

F 14532 FS0047 05/2023



# PRODUCT SPECIFICATIONS

# HYMAX® 2)

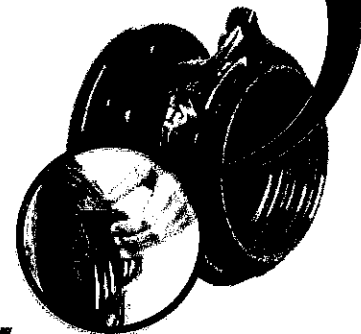

## FLANGE ADAPTOR (1.5"-12")<sup>\*</sup> AND FLANGE ADAPTOR LONG BODY (1.5"-12")

### FEATURES

- ADVANCED WIDE-RANGE COUPLING WITH A PATENTED FLIP GASKET
- ELIMINATES GASKET REMOVAL MISTAKES AND MAXIMIZES INSTALLER WORK EFFICIENCY
- USING THE GAME-CHANGING HYMAX TECHNOLOGY, PROVEN IN OVER 1M INSTALLATIONS IN THE US
- SUITABLE FOR ALL TYPES OF PIPES - DUCTILE IRON, CAST IRON, STEEL, COPPER, PE, PVC, AC, GRP
- PATENTED HYDRAULICALLY-ASSISTED GASKET WITH 2-STAGE SEALING
- LIGHTWEIGHT CONSTRUCTION ENABLES FAST AND EASY INSTALLATION
- ALLOWS 4° DYNAMIC DEFLECTION, REDUCING FUTURE PIPE DAMAGE

### SPECIFICATIONS

#### STANDARDS

HYMAX FLANGE ADAPTOR AND LONG BODY MEETS OR EXCEEDS REQUIREMENTS OF STANDARDS: AWWA C-219, NSF-61, NSF 372.

#### SIZE

AVAILABLE IN NOMINAL DIAMETER  
FLANGE ADAPTOR 1.5"-12"  
FLANGE ADAPTOR LONG 1.5"-12"

#### MATERIAL

**FLANGE BODY** ASTM A53 GRADE A STEEL.

**FLANGE** F/A Meets ANSI B16.5, Class 150.  
F/A Long 1.5"-2" OVAL FLANGE FOR FLOW METER  
3" Meets ANSI B16.5  
4"-12" Meets AWWA class D

**END RING** ASTM A283 / A283M GRADE C STEEL.

**SPHERICAL SPACERS** AVAILABLE IN AISI 304 OR SS316<sup>\*\*</sup> STAINLESS STEEL

**BRIDGE** AVAILABLE IN AISI 304 OR SS316<sup>\*\*</sup> STAINLESS STEEL

**GASKET** EPDM COMPOUNDED FOR WATER AND SEWAGE, MEETS INTERNATIONAL STANDARDS FOR CONTACT WITH DRINKING WATER.

**COATING** 100% FUSION BONDED EPOXY FOR ENHANCED CORROSION PROTECTION. AVERAGE THICKNESS 14 MIL.

**NUTS & BOLTS** AVAILABLE IN AISI 304 OR SS316<sup>\*\*</sup> STAINLESS STEEL. ROLLED THREAD AND ANTI-GALLING COATING.

\* REGISTERED PATENT

\*\* SS316 Coming Soon

# HYMAX®

Repair the past. Connect the future.

KRAUSZ is the creator of HYMAX

# PRODUCT SPECIFICATIONS

## HYMAX 2

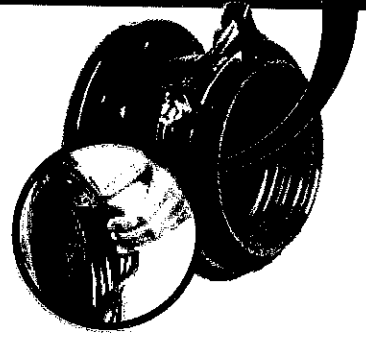

Flange Adaptor / Flange Adaptor Long  
 1.5"-12"                      1.5"-12"

### PRODUCT PERFORMANCE

<b>WORKING TEMPERATURE</b>	EPDM: -20°F UP TO +125°F
<b>DYNAMIC DEFLECTION</b>	UP TO 4°
<b>MIN. PIPE INSERTION</b>	2.25"
<b>MAXIMUM OFFSET FOR MISALIGNED PIPES</b>	<b>F/A</b> ND 1.5"-3"    ND 4"-12" 0.20"            0.24"
	<b>F/A LONG</b> ND 2"-3"      ND 4"-12" 0.20"            0.24"
<b>MAXIMUM OUT OF ROUNDNESS</b>	<b>F/A</b> ND 1.5    ND 2"-3"    ND 4"-12" 0.08"    0.20"      0.31"
	<b>F/A LONG</b> ND 1.5    ND 2"-3"    ND 4"-12" 0.08"    0.20"      0.31"
<b>WORKING PRESSURE</b>	175 PSI
<b>RATED PRESSURE</b>	262 PSI
<b>VACUUM TEST</b>	12 PSI